

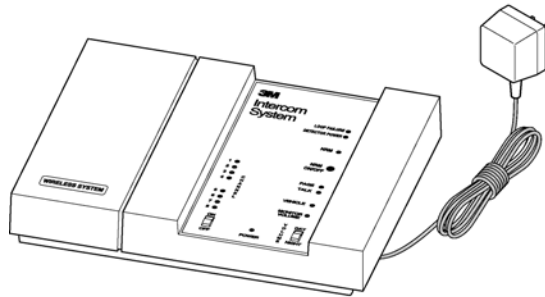

# Headset Intercom System

Model C1060

## Installation Instructions



**Base Station**



**Headset**

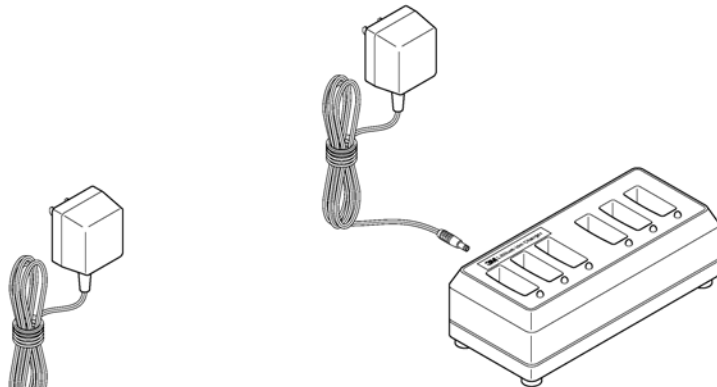

**6-Slot Battery Charger**

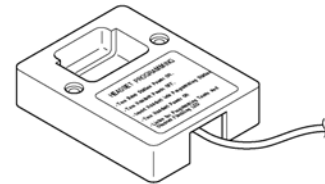

**Programming Station**

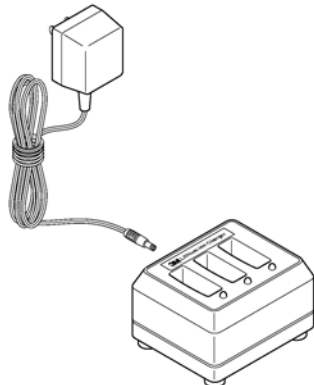

**3-Slot Battery Charger**

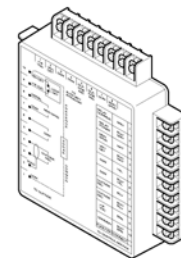

**Interconnect Module**

C1060-01A



# Table of Contents

Safety Information.....	iii
Intended Use .....	iii
FCC Information .....	iv
Typical Single Lane Installation.....	1
Battery Charger .....	2
Speaker and Microphone Assemblies.....	3
Standard Systems .....	3
Duplex Systems .....	3
Base Station.....	3
Programming Station.....	4
Connecting the Base Station Directly to Components .....	5
Connecting the Base Station to Components Using the Optional Interconnect Module.....	6
Connecting the Auxiliary Intercom (Optional) .....	8
Dual Lane System Installation.....	9
Cross Lane System Installation .....	10
Installation.....	11
Wiring the System .....	11
Programming the Headsets for Cross-Lane Operation.....	11
Operation.....	12
System Configurations and Function Jumper Settings.....	14
Standard Operation – Single Lane System (One Base Station) .....	14
Standard Operation – Dual Lane System (Two Base Stations) .....	14
Duplex Operation – Single Lane System (One Base Station).....	15
Duplex Operation – Dual Lane System (Two Base Stations).....	15
Channel Selection.....	16
Setting Audio Levels .....	17
Duplex Systems Only .....	18
Duplex <i>and</i> Standard Systems .....	18
Alert Tone Level.....	18
Monitor Speaker Volume Levels.....	19
Standard Systems Only .....	19
Listen Level (Menu Sign Microphone Sensitivity) .....	19
Menu Sign Talk Volume Level .....	20

## Table of Contents (continued)

Circuit Board Jumpers, Adjustment Controls, Indicators and Switches .....	21
Jumpers .....	21
Adjustment Controls .....	22
Indicators .....	22
Switches (etc.) .....	23
Connectors .....	23
Finishing Up .....	24
Troubleshooting Audio Feedback .....	24
Technical Assistance .....	24

## Illustrations

Figure 1. Typical Installation .....	1
Figure 2. Battery Chargers (3-Slot and 6-Slot Versions) .....	2
Figure 3. Base Station Mounting Holes .....	3
Figure 4. Programming Station Mounting Holes .....	4
Figure 5. Direct Base Station-to-Component Connections .....	5
Figure 6. Base Station – Interconnect Module Connections .....	6
Figure 7. Connecting Components to the Interconnect Module .....	7
Figure 8. D-15D (M478 DA) Connections .....	8
Figure 9. D-15B and D-15C (M478 BA and CA) Connections .....	8
Figure 10. D-30 Connections .....	9
Figure 11. Cross-Lane Wiring Diagram .....	11
Figure 12. Removing the Half-Cover from the Base Station .....	16
Figure 13. Base Station Circuit Board .....	17
Figure 14. Base Station Circuit Board .....	21

# SAFETY INFORMATION



## Safety Rules for C1060 Installation Instructions & C1060 Operating Instructions



Read, understand, and follow all safety information contained in these instructions prior to installation & operation of the 3M Headset Intercom System, Model C1060. Failure to follow all instructions listed could result in electrical shock, fire and/or other personal injury. Retain these instructions for future reference.

### Intended Use:

The 3M Headset Intercom System Model C1060 is intended for use to provide 2-way radio-frequency audio communication in quick service drive-through restaurants and convenience stores.

The system must be installed as specified in the Model C1060 Installation Instructions and operated as specified in Model C1060 Operating Instructions in quick service drive-through restaurants and convenience stores. It has not been evaluated for other uses or locations.

EXPLANATION OF SIGNAL WORD CONSEQUENCES	
 <b>WARNING:</b>	Indicates a potentially hazardous situation, which, if not avoided, could result in death or serious injury and/or property damage.
 <b>CAUTION:</b>	Indicates a potentially hazardous situation, which, if not avoided, may result in minor or moderate injury and/or property damage.
<b>CAUTION:</b>	Indicates a potentially hazardous situation, which, if not avoided, may result in property damage.

EXPLANATION OF PRODUCT SAFETY LABEL SYMBOLS	
	<b>Attention:</b> Read accompanying documentation
	<b>Warning:</b> Risk of Electric Shock

### ✓ IMPORTANT NOTES

Important notes are used in the C1060 Installation Instructions and C1060 Operating Instructions to denote system function or performance information.

## WARNING

### To reduce the risks associated with hazardous voltage:

- Disconnect power to the receptacle before installing or removing the Base Station Power Supply. When removing receptacle cover screw, cover may fall across plug pins or receptacle may become displaced. Use only with duplex receptacle having center screw. Secure unit in place by receptacle cover screw.
- If power supply is supplied with a grounding pin, connect directly to a grounding receptacle - 3 prong.
- Use inside in a dry location only.

### To reduce the risks associated fire & property damage:

- Do not open, crush, expose to heat above 200 F or incinerate the battery.
- Always replace batteries, battery chargers and power supplies with 3M approved units acceptable for use in this system to avoid system function & safety concerns.

## CAUTION

### To reduce the risks associated with environmental contamination due to battery pack & to lead in the solder:

- Dispose of batteries, power supplies, battery charger and base station in accordance with federal, state & local requirements. If preferred, return these components to 3M Service Center for disposal.

## IMPORTANT INFORMATION

- Clean battery, battery charger & headset contacts with a water moistened cotton swab.
- Recommend turning the headset off then back on (which automatically sets the volume to mid level) then adjust volume to preferred level prior to each user change.
- For communications equipment sales and service, contact your local 3M authorized intercom dealer. If special service assistance is needed, or for information on how to properly dispose of your non-functional C1060 rechargeable batteries, please call (800) 328-0033. For more information, visit the 3M Foodservice Web site: <http://www.3m.com/foodservice>

## FCC INFORMATION

This device complies with part 15 of the FCC Rules listed ID HCQ3B63MH3, Canada 2309104369A and Australia & New Zealand AS4268.2.1995 & AS3548.1995.A2.1997. Operation is subject to the following two conditions: (1) This device may not cause harmful interference, and (2) this device must accept any interference received, including interference that may cause undesired operation. These limits are designed to provide a reasonable protection against harmful interference when the equipment is operated in a commercial environment. This equipment generates, and can radiate radio frequency energy and, if not installed and used in accordance with the instruction manuals, may cause harmful interference to radio communications. Changes or modifications not expressly approved by the party responsible for compliance could void the user's authority to operate the equipment.



## Battery Charger

Install the battery charger and begin charging the batteries before you install any other components.

Install the battery charger in a clean, dry environment. An office location is best.

The battery charger may be placed on a flat surface such as a table, desk, etc., or it can be fastened to a wall using the optional wall-mount kit.

Plug the power supply transformer into a 120-Volt wall outlet and then plug the transformer cord into the connector in the end of the battery charger. The three green lights on the battery charger will turn on.

To charge a battery, plug it into the charger as shown in Figure 2. Observe the charging status indicator next to the battery:

- The indicator lights RED to indicate the battery is charging.
- The indicator lights GREEN to indicate the battery is fully charged.

<b>✓ Important Note</b>
Discharged batteries require 1-1/2 to 2 hours to charge.

When the battery voltage becomes too low, a short, low volume tone, occurring at seven-second intervals is heard in the headset. This repeating tone continues for two minutes. After the two-minute interval, the headset automatically turns off to prevent battery damage.

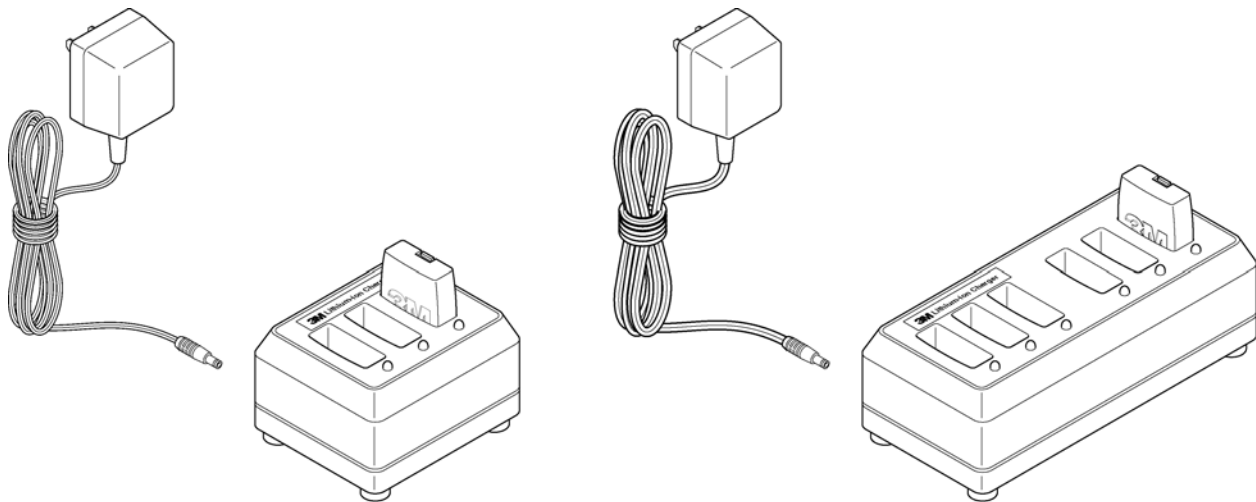

C1069-05A

**Figure 2. Battery Chargers (3-Slot and 6-Slot Versions)**

# Speaker and Microphone Assemblies

## Standard Systems

For standard systems, install the Deluxe 5-Inch Speaker and Microphone Assembly, Part Number 78-6911-1545-1. Refer to the installation instructions packaged with the assembly.

## Duplex Systems

For duplex systems, install the 3.5-Inch Duplex Microphone (with foam housing), Part Number 78-6911-4476-6 **and** the 5-Inch Metal Speaker Assembly, Part Number 78-6911-4411-3. Refer to the installation instructions packaged with the assemblies.

## Base Station

1. For proper system operation, locate the base station module:
  - 5 to 6 feet above the floor
  - at least 10 feet from the cashier/drive-thru window
  - At least 3 feet from large metal objects such as refrigerators, ranges, coolers, etc., and other metal or electrical devices.

<b>✓ Important Note</b>
Do not mount base station under steel countertops, within 3 feet of coolers/refrigerators/ranges or in areas where it will be obscured by steel doors, walls, etc. as this will cause operational problems.

2. Mount the base station using the included screws and anchors. (See Figure 3.)

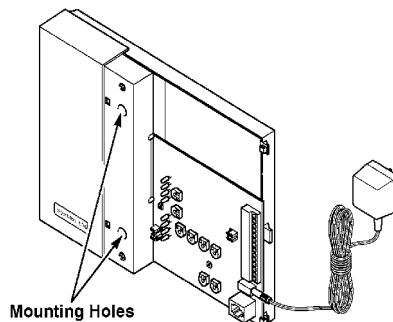

**Figure 3. Base Station Mounting Holes**

3. Install conduit and cable clamps as necessary.
4. Feed the cables for speaker, microphone, vehicle detect and monitor speaker (if used) through the conduit down to the interconnect module or base station. (See Figure 1.)
5. Feed the transformer cable from the outlet to the base station. (See Figure 1.)

Keep the transformer cable at least 6 inches from the left half of the base station. This half contains sensitive radio components which will be affected if the cable is too close.

## Programming Station

1. For proper system operation, locate the programming station module 18 inches or less from the base station. An 18 inch cable is provided to connect between the base station and the programming station.

✓ Important Note
Allow enough room below the programming station to allow insertion of the headset while it is being programmed. Do not mount programming station too close above the countertop or other wall-mounted object.

2. Mount the programming station module using the included screws and anchors. (See Figure 4.)

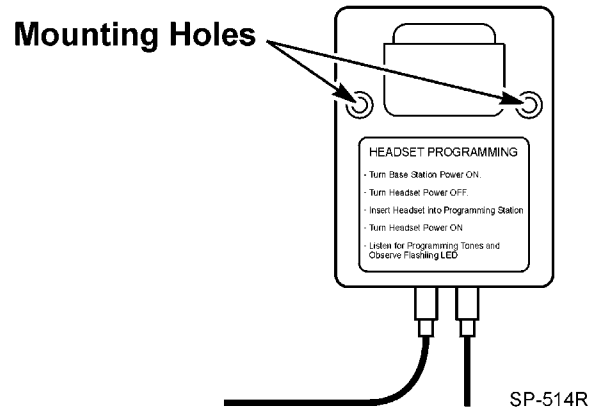

**Figure 4. Programming Station Mounting Holes**

3. Connect the 18 inch long programming cable provided between the base station programming jack and the programming station jack.
4. If needed, connect the programming cable for use with C860 and C960 headsets and allow it to hang from the programming station

## Connecting the Base Station Directly to Components

If an interconnect module is not used, connect the components (vehicle detector, speaker/microphone and optional monitor speaker) directly to the base station as shown in Figure 5. Use 18–20 gauge twisted pair audio wire for all connections except the microphone. Use an 18–20 gauge shielded twisted-pair of audio wire for the connection to the microphone.

**✓ Important Note**

The twisted-pair of wires for the microphone connection must be shielded for proper operation. In duplex systems, microphone and speaker cannot be in the same jacket unless specially designed for duplex such as 3M 78-8095-0180-8.

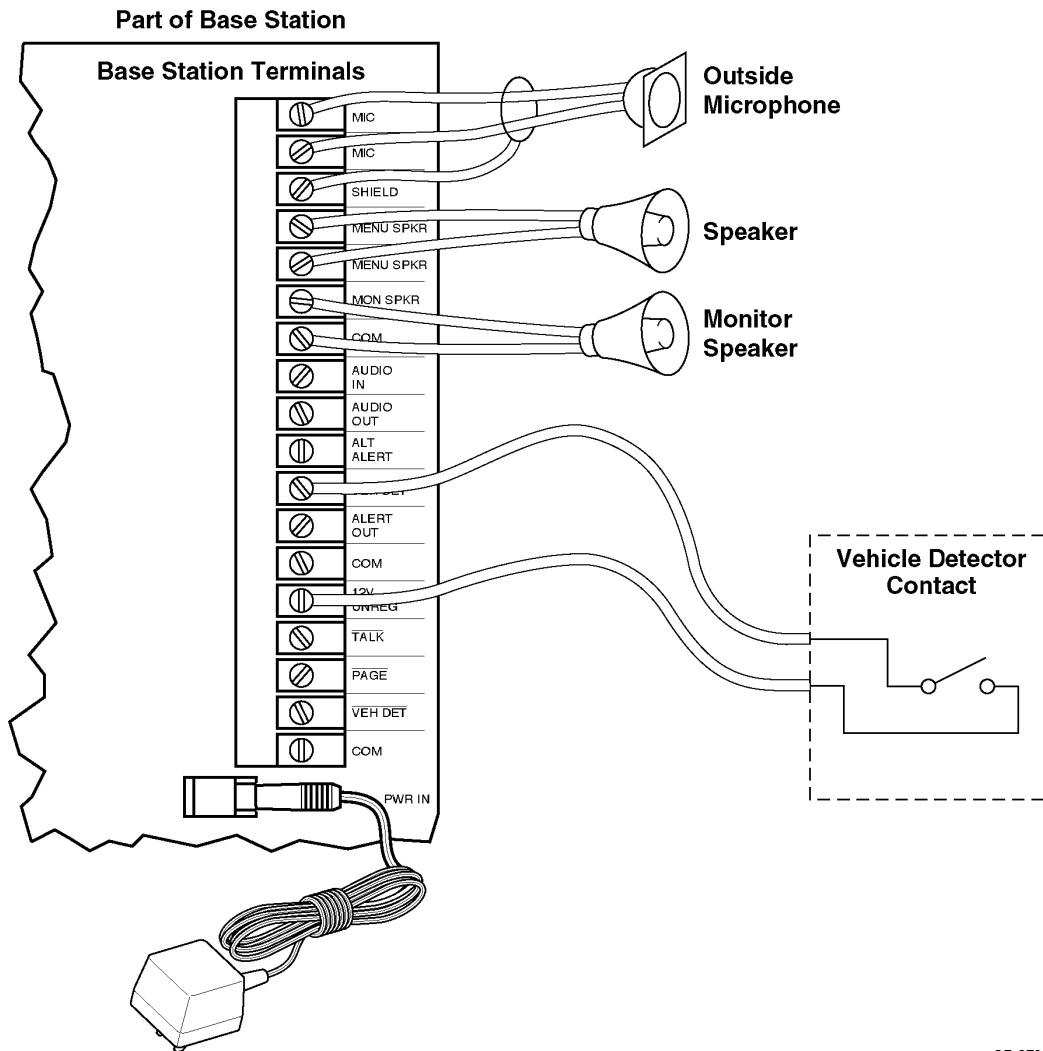

SP-379A

**Figure 5. Direct Base Station-to-Component Connections**

# Connecting the Base Station to Components Using the Optional Interconnect Module

Connect the base station to the interconnect module as shown in Figure 6. Note that the connections are made to the “TO CONTROL MODULE” terminals on the interconnect module.

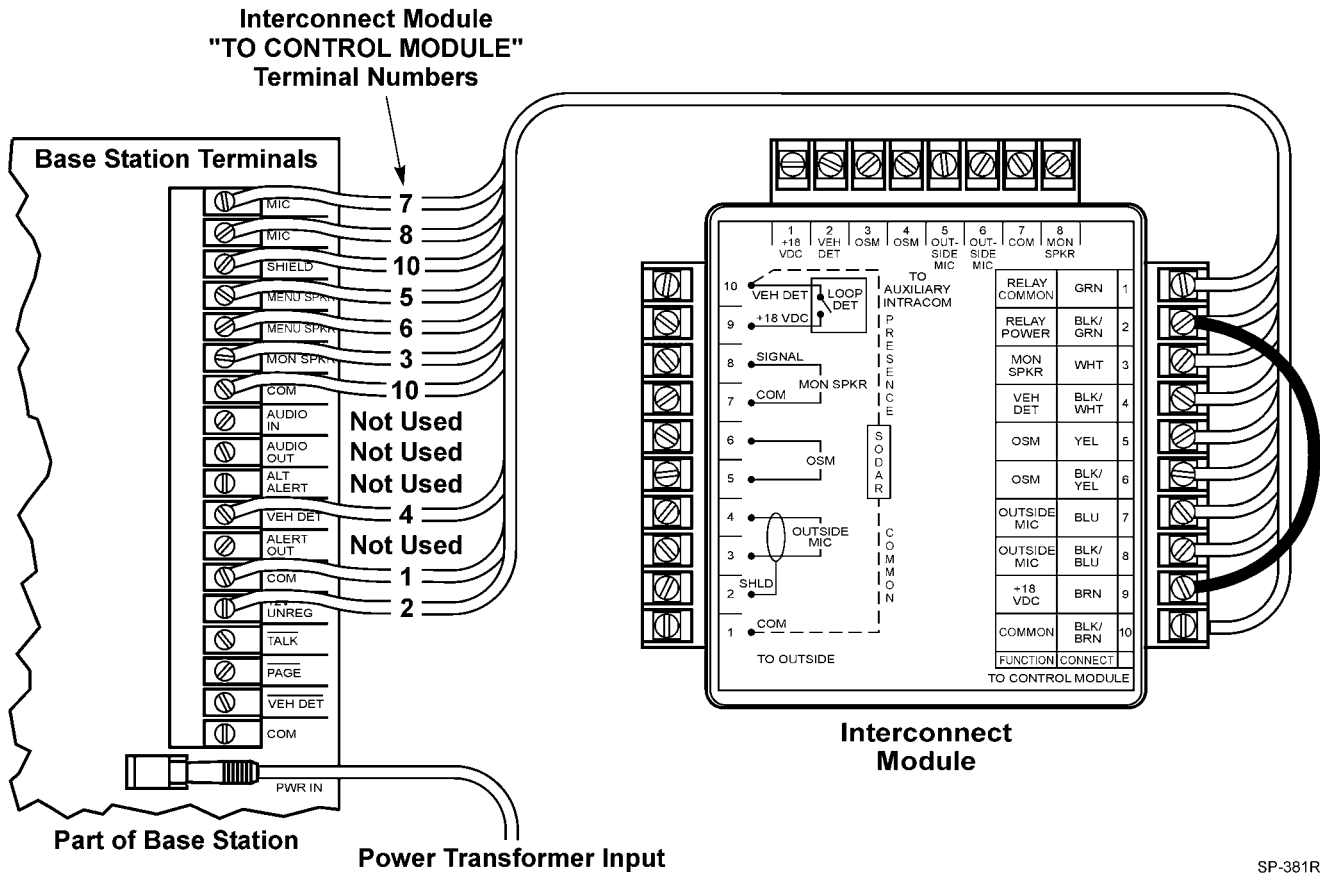

Figure 6. Base Station – Interconnect Module Connections

Connect the components (vehicle detector, speaker/microphone, and optional monitor speaker) to the interconnect module as shown in Figure 7. Note that the connections are made to the “TO OUTSIDE” terminals on the interconnect module.

**✓ Important Note**

If an optional back-up (auxiliary) intercom is connected to the “TO AUXILIARY INTERCOM” on the interconnect module, the base station must be turned off to enable operation/usage of the back-up intercom.

Use 18–20 gauge twisted-pair audio wire for all connections except the microphone. Use an 18–20 gauge **shielded** twisted-pair audio wire for the connection to the microphone.



## Connecting the Auxiliary Intercom (Optional)

**✓ Important Note**

The base station must be turned off to enable operation/use of the auxiliary intercom.

1. Connect the auxiliary intercom to the “TO AUXILIARY INTERCOM” terminals on the interconnect module as shown in Figure 8 through Figure 10 (depending on the model of intercom used).

The presence alert shown is wired to operate only when the Model C1060 is turned off.

If a separate outside microphone is used, the auxiliary intercom must be configured for OUTSIDE MIC. Refer to the Auxiliary Intercom Installation Instructions for information about moving any internal jumpers.

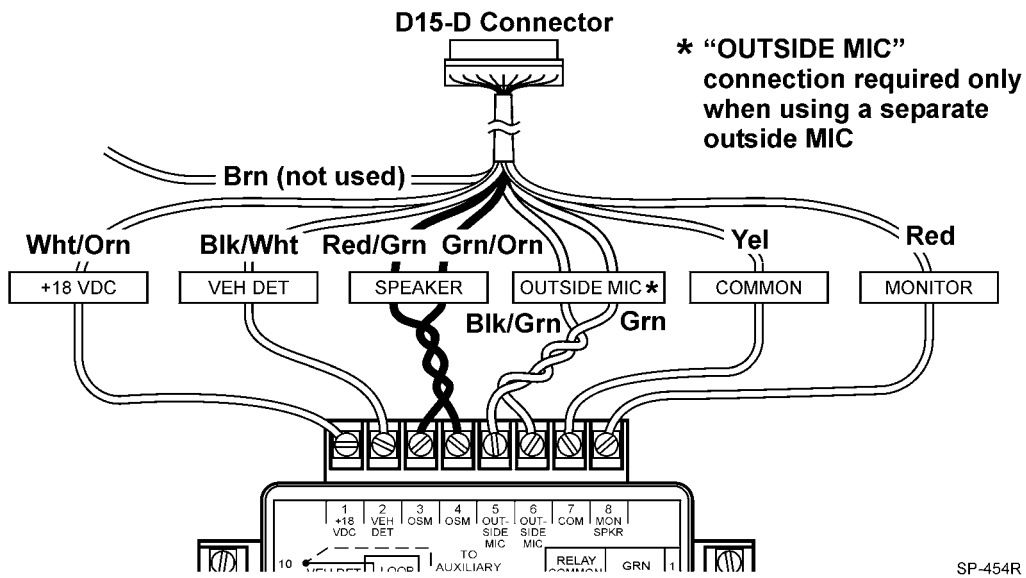

**Figure 8. D-15D (M478 DA) Connections**

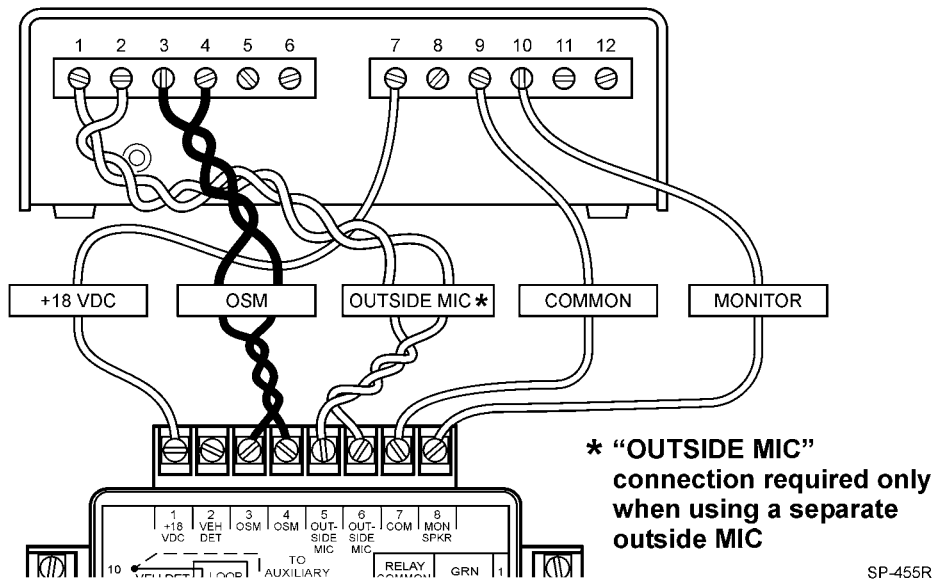

**Figure 9. D-15B and D-15C (M478 BA and CA) Connections**

✓ Important Note

If you use a D-30 as the auxiliary intercom, a separate monitor speaker must be provided for the Model C1060. (Both the Model C1060 and D-30 intercoms require separate monitor speakers.)

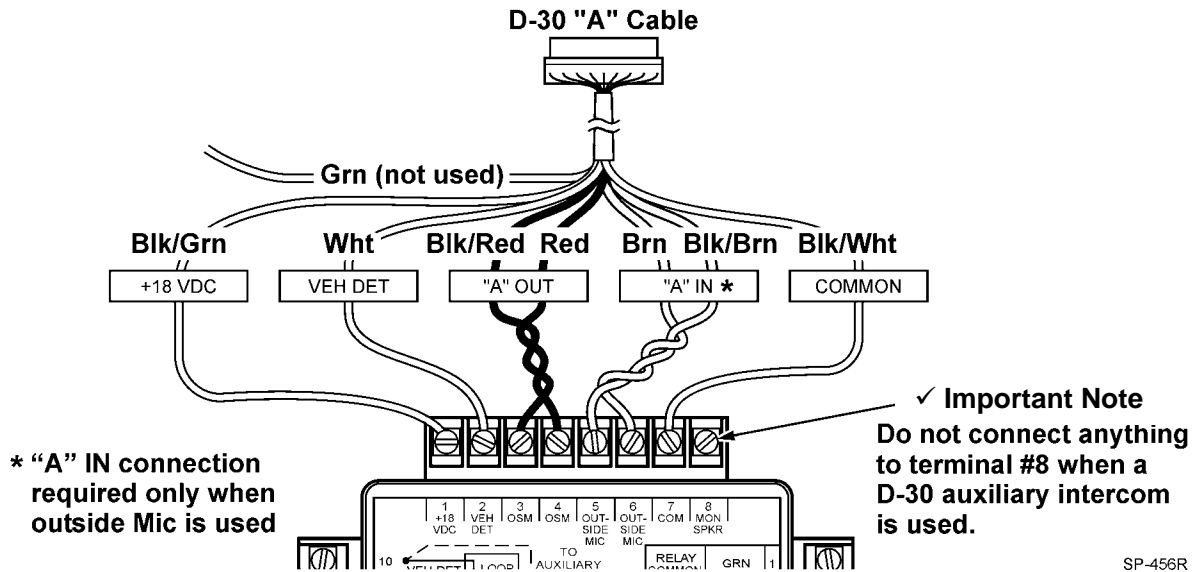

## Dual Lane System Installation

A dual lane system consists of two separate single lane systems that operate independently of each other. Each single lane system has its own dedicated base station and headset(s).

To install a dual lane system:

1. Install two single lane systems as outlined in these installation instructions.

✓ Important Note

Base station models C921 and earlier must be mounted at least 25 feet apart.  
Base station models C922 may be mounted as close as 2 feet apart.

2. With the base stations turned off, set jumper J3 on one of the base stations so that it jumpers pins 1 and 2. This designates the base station as a lane 1 system.
3. Set jumper J3 on the other base station so that it jumpers pins 2 and 3. This designates the base station as a lane 2 system.

✓ Important Note

Do not set both base stations to the same lane number as this will cause operational problems.

4. Turn on both base stations and press the RESET SWITCH on each of the base station circuit boards to “read” the jumper setting into the microprocessor.
5. Select a channel for each of the base stations. (See page 15 for the channel selection procedure.) After you select the channel, press the RESET SWITCH on the base station circuit boards to “read” the selection into the microprocessor.

6. Re-program the headsets as instructed on page 16.
7. Check the operation of each of the systems. Note that the alert tone for the Lane 1 system headsets is a single repeating “beep” while the alert tone for the Lane 2 system headsets is a double repeating “beep.”

## **Cross-Lane System Installation**

The Cross-Lane system provides communication for facilities that have two menu signs. It consists of two base stations that are connected to a Cross-Lane Module. A Cross-Lane Module is a five-pole switch that allows the two systems to be separated during hours of peak activity. Refer to the installation instructions (Document Number 78-6912-0487) included with the Cross Lane Module (P/N78-6911-4396-6). These instructions are also located in the Wireless Intercom Service Manual.

A Cross-Lane Module can be useful if the manager wishes to operate each lane with a separate crew during periods of peak activity. This is accomplished by turning the Cross-Lane switch **OFF**. By pressing the **T1** button on any headset, the operator can communicate with a customer at menu sign 1. By pressing the **T2** button on any headset, another operator can communicate with a customer at menu sign 2. When the Cross-Lane Module is **OFF**, the operator will only hear the vehicle detector alert from the menu sign with which he or she last talked.

During periods of lower activity, the Cross-Lane Module is turned **ON**, allowing one headset order-taker to operate both lanes. When the cross-lane module is turned **ON**, the operator will always hear vehicle detector alerts from both menu signs. A single alert indicates a vehicle is at menu sign 1 while a double alert indicates a vehicle is at menu sign 2.

# Installation

✓ **Important Note**

Both base stations must be set to the same channel number and different lane numbers.

Base station models C921 and earlier must be mounted at least 25 feet apart. Base station models C922 may be mounted as close as 2 feet apart. Test the system prior to installation by placing the base stations in the desired locations. Set Jumpers and program the headsets. Insure that the talk L.E.D. on the proper base station lights when the appropriate (T1 and T2) button on the headset is pressed.

## Wiring the System

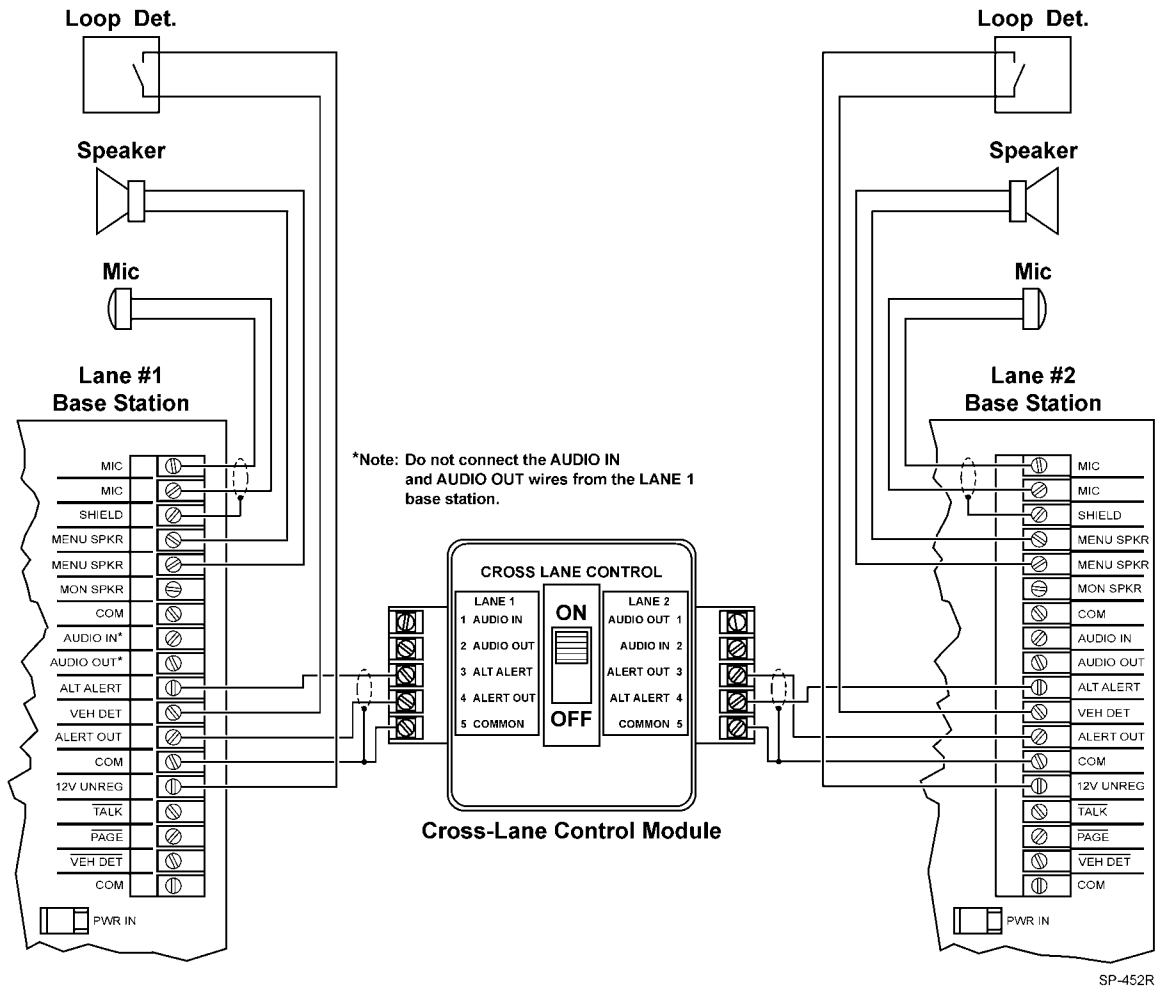

**Figure 11. Cross-Lane Wiring Diagram**

## Programming the Headsets for Cross-Lane Operation

Follow the steps below to program the headsets for Cross-Lane operation, and disable the Talk-Lock function. It does not matter which base station is used to program the headsets. By pressing **T1**, the headset will always communicate with the lane 1 base station; by pressing **T2**, the headset will always communicate with the lane 2 base station.

### 1. Disable the Talk Lock function

Talk-Lock is a toggle function that must be checked first to see if it is enabled or disabled. If the Talk LED lights when the **L** button is pressed, Talk-Lock is enabled.

- To disable Talk-Lock, turn the headset OFF, press and hold the **L** button while pressing ON for 5 seconds. You will hear an acknowledging beep.
- Recheck the Talk-Lock function by pressing the **L** button. The Talk LED on the base station should not light.

## 2. Program the Headsets for Cross-Lane Operation

- With the headset OFF, press and hold **T1** and **T2** while pressing ON for 5 seconds. You will hear an acknowledging beep.
- Verify that the headsets are properly programmed for Cross-Lane operation:
  - Press **T1** and verify that the Talk LED lights on the lane 1 base station and does not light on the lane 2 base station.
  - Press **T2** and verify that the Talk LED lights on the lane 2 base station and does not light on the lane 1 base station.
- To remove the Cross-Lane function and return the headsets to the normal operating mode, first turn the headset **OFF**, and then hold down **T1** while pressing **ON** for 5 seconds. You will hear an acknowledging beep.

## Operation

### Cross-Lane Module OFF

#### *Vehicle detector alerts*

The operator will only hear the vehicle detector alert from the menu sign with which he or she last talked. Vehicles at menu sign 1 will be heard as a single repeating alert. Vehicles at menu sign 2 will be heard as a double repeating alert.

#### *Answering customers*

Pressing **T1** will only allow communication with the lane 1 customer. Pressing **T2** will only allow communication with the lane 2 customer.

#### *Paging function*

Pressing **T1** will only allow communication with other headsets, which recently pressed **T1**. Pressing **T2** will only allow communication with other headsets, which recently pressed **T2**.

### Cross-Lane Module ON

#### *Vehicle detector alerts*

The operator will always hear both vehicle detector alerts. Vehicles at menu sign 1 will be heard as a single repeating alert. Vehicles at menu sign 2 will be heard as a double repeating alert.

#### *Answering customers*

Pressing **T1** will only allow communication with the lane 1 customer. Pressing **T2** will only allow communication with the lane 2 customer.

#### *Paging function*

Pressing **T1** will only allow communication with other headsets, which recently pressed **T1**. Pressing **T2** will only allow communication with other headsets, which recently pressed **T2**.

## ✓ Important Notes

### 1. Both vehicle alert tones will be heard at all times with the Cross-Lane Module ON

The order-taker may object to hearing the vehicle alert from the other lane while taking an order; if so, we suggest you decrease ALERT TONE LEVEL on each base station so it is audible in the headsets but not objectionable. The tone should be low enough so that the order-taker can ignore it, yet know that someone is waiting at the other lane.

### 2. Listening and Paging in a Cross Lane system

With the AUDIO IN and AUDIO OUT wires disconnected, the **T1** and **T2** buttons control which menu sign to talk or listen to. They also control which headsets to PAGE to. Disconnecting the AUDIO IN and AUDIO OUT wires presents some issues if a cook or cashier needs to monitor both lanes:

- If the cook or cashier is using a headset to monitor lane 1, and the order-taker is taking an order from menu lane 2, or if the order-taker needs to PAGE the cashier, he/she must first press T1 momentarily, then press PAGE to communicate privately with the cashier on lane 1. Then the order-taker can press T2 to resume taking the order on lane 2.
- As an alternative, a monitor speaker from each base station may be installed in the kitchen. (Caution: Monitor speakers are generally not recommended for duplex systems using C921AA base stations. The speaker location and volume are usually too critical to avoid feedback. C921BA and C922 base stations can usually be configured successfully to allow operation of monitor speakers.)

### 3. The vehicle alerts may echo in the headsets

With the Cross-Lane module turned ON, two rapid single tones may be heard from the lane 1 base station. To eliminate this problem, turn down the volume of the ALERT TONE LEVEL control, on one of the base stations.

## System Configurations and Function Jumper Settings

### ✓ Important Note

Whenever a jumper setting is changed, the RESET SWITCH on the base station circuit board must be pressed to program the new jumper setting into the microprocessor. Also, each of the headsets in the system must be reprogrammed when a jumper setting is changed (see Channel Selection on page 13 for the headset programming procedure).

Determine the system type (standard operation – single lane, etc.) and identify the type of speaker (speaker only **or** speaker and microphone) and the type of vehicle detector (air switch **or** loop/SODAR detector).

Refer to the base station circuit board illustration (Figure 14) and the applicable system configuration below. Set the function jumpers as noted and per the type of speaker and vehicle detector in the system. (An illustration of the circuit board also appears on the decal inside of the base station half-cover.)

### Standard Operation – Single Lane System (One Base Station)

Function	Jumper Settings
Menu Sign with Speaker only (OSM)	Jumper pins 1 and 2 on jumpers J1 <u>and</u> J2.
<b>or</b>	<b>or</b>
Menu Sign with Separate Speaker and Microphone	Jumper pins 2 and 3 on jumpers J1 <u>and</u> J2.
Lane 1 System	Jumper pins 1 and 2 of jumper J3.
Air Switch (Pulse) Detector	Jumper pins 1 and 2 of jumper J4.
<b>or</b>	<b>or</b>
Loop/Sodar (Presence) Detector	Jumper pins 2 and 3 of jumper J4.
Standard Operation	Jumper pins 2 and 3 of jumper J5.
Menu Power Selection	Jumper <b>must</b> cover the top 2 pins of jumper J6.
Talk Monitor Level	Jumper left 2 pins of jumper J9.

### Standard Operation – Dual Lane System (Two Base Stations)

Function	Jumper Settings
Menu Sign with Speaker only (OSM)	Jumper pins 1 and 2 on jumpers J1 <u>and</u> J2.
<b>or</b>	<b>or</b>
Menu Sign with Separate Speaker and Microphone	Jumper pins 2 and 3 on jumpers J1 <u>and</u> J2.
Lane 1 System	Jumper pins 1 and 2 on base station 1, jumper J3.
Lane 2 System	Jumper pins 2 and 3 on base station 2, jumper J3.
Air Switch (Pulse) Detector	Jumper pins 1 and 2 of jumper J4.
<b>or</b>	<b>or</b>
Loop/Sodar (Presence) Detector	Jumper pins 2 and 3 of jumper J4.
Standard Operation	Jumper pins 2 and 3 of jumper J5.
Menu Power Selection	Jumper <b>must</b> cover the top 2 pins of jumper J6.
Talk Monitor Level	Jumper left 2 pins of jumper J9.

## Duplex Operation – Single Lane System (One Base Station)

Function	Jumper Settings
Menu Sign with Separate Speaker and Microphone	Jumper pins 2 and 3 on jumpers J1 <u>and</u> J2.
Lane 1 System	Jumper pins 1 and 2 of jumper J3.
Air Switch (Pulse) Detector	Jumper pins 1 and 2 of jumper J4.
<b>or</b>	<b>or</b>
Loop/Sodar (Presence) Detector	Jumper pins 2 and 3 of jumper J4.
Duplex Operation	Jumper pins 1 and 2 of jumper J5.
Menu Power Selection	Jumper bottom 2 pins of jumper J6.
Talk Monitor Level	Jumper left 2 pins of jumper J9.
	<b>or</b>
	If customer desires, jumper right 2 pins of jumper J9.
SWT Threshold (High)	Jumper CRFT 2 pins when using a C1060 headset in Talk Lock mode.
SWT Threshold (NRML)	Jumper right 2 pins for all configurations except those mentioned in “High.”

## Duplex Operation – Dual Lane System (Two Base Stations)

Function	Jumper Settings
Menu Sign with Separate Speaker and Microphone	Jumper pins 2 and 3 on jumpers J1 <u>and</u> J2.
Lane 1 System	Jumper pins 1 and 2 on base station 1, jumper J3.
Lane 2 System	Jumper pins 2 and 3 on base station 2, jumper J3.
Air Switch (Pulse) Detector	Jumper pins 1 and 2 of jumper J4.
<b>or</b>	<b>or</b>
Loop/Sodar (Presence) Detector	Jumper pins 2 and 3 of jumper J4.
Duplex Operation	Jumper pins 1 and 2 of jumper J5.
Menu Power Selection	Jumper bottom 2 pins of jumper J6.
Talk Monitor Level	Jumper left 2 pins of jumper J9.
	<b>or</b>
	If customer desires, jumper right 2 pins of jumper P9.

## Channel Selection

The Model C1060 Headset Intercom System can operate on any one of eight different channels.\*

Select a channel that neither receives or causes interference and then program the headsets to that channel using the following procedure:

1. Pull slightly outward on the lower right side of the base station half-cover and then lift and remove the cover as shown in Figure 12.

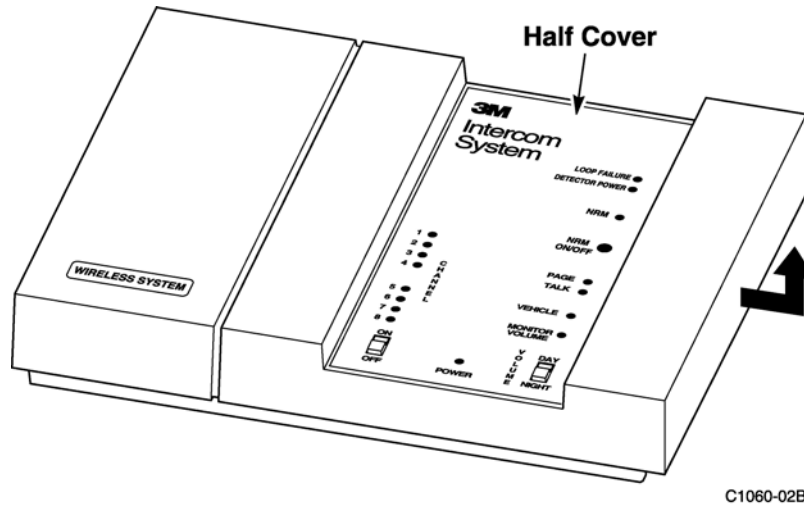

**Figure 12. Removing the Half-Cover from the Base Station**

2. With the base station turned on, press and release the CHANNEL SELECT switch once. (This advances the system to the next channel.) One of the red indicators (1–8) will light, indicating the newly selected channel.

**✓ Important Note**

After making any changes to the base station jumper settings, you must press the RESET SWITCH to “read” the new settings into the microprocessor.

**✓ Important Note**

When two systems are used in a *dual lane application*, each base station **must** be set to the same channel, and one base station must be set to Lane 1 and the other to Lane 2.

**✓ Important Note**

If you are installing this as a single lane system, 8 channels on the LANE 2 setting are also available for use.

## Channel Selection (Cont.)

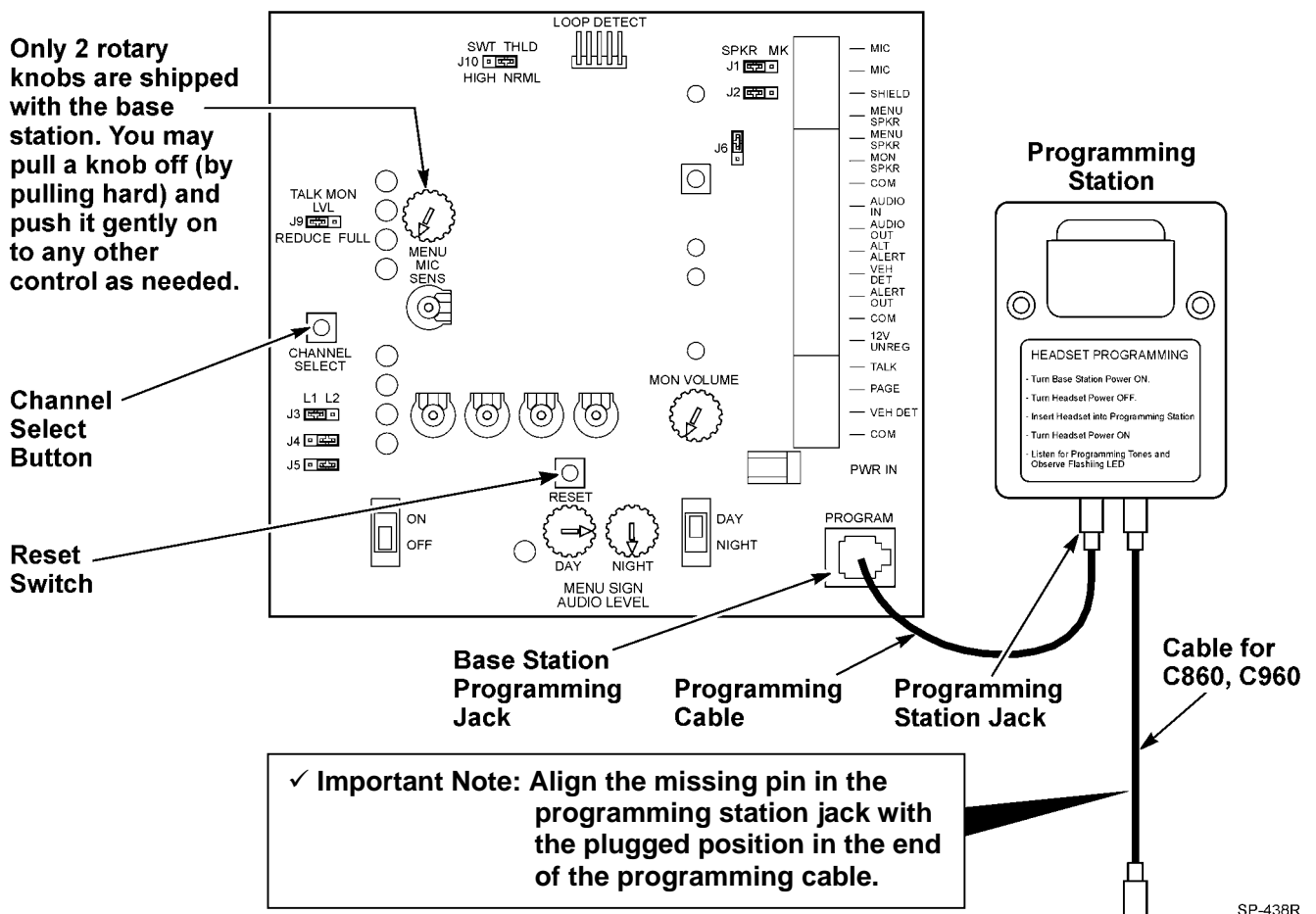

**Figure 13. Base Station Circuit Board**

3. With the headset/belt pack turned off, plug one end of the programming cable into the headset programming jack.
4. Plug the other end of the programming cable into the base station modular jack.
5. Turn on the headset/belt pack. (Audible tones will be heard in the headset earpiece indicating that programming is complete.)

The headset/belt pack is now programmed to the same channel as the base station.

Repeat the channel selection procedure if interference occurs. After seven channel changes, the original channel will again be encountered. If interference is still present and the system is a single lane system, try changing the J3 lane designation jumper from lane 1 to lane 2. If this fails and none of the channels are interference free, contact your 3M representative.

## Setting Audio Levels

To set the audio levels, refer to the related audio level procedure below and to the illustration of the base station circuit board (Figure 14). All the audio level adjustment controls are located on the base station circuit board. (An illustration of the circuit board also appears on the decal mounted to the base station.)

## Duplex Systems Only

The following procedure sets system audio levels for duplex systems so that headset/belt pack volume controls have enough “range” to allow operators to adjust headset volume to their preference.

<b>✓ Important Note</b>
The microphone at the menu sign must be located within four feet of the vehicle for duplex operation.

To set the audio levels:

1. Turn the base station MENU MIC SENS control to minimum (CCW).
2. Adjust the headset volume control to maximum.
3. Press the headset **T**alk switch, and set the base station outbound (DAY/NIGHT) audio levels to the desired level at the post/sign.
4. Press and hold the headset/belt pack **T**alk switch, and turn the base station MENU MIC SENS control up (CW) until feedback occurs. Then turn the MENU MIC SENS level control down (CCW) until the feedback stops.
5. Check each additional headset/belt pack (to be used in the system) at maximum volume. Verify that feedback does **not** occur. If feedback occurs, adjust the MENU MIC SENS level down until the feedback stops.
6. Lower the volume control on the headset/belt pack 2 levels from maximum, and check that the inbound audio level from the menu mic is usable. If everything is all right, the audio will be too loud.
7. Compare this inbound listen level in the headset to the page audio level from another headset.
8. Adjust the MENU MIC SENS level down (never up) to match the page audio level as required.
9. If the inbound listen level cannot be made to match the page audio level, then more acoustic isolation is needed for the menu mic and menu speaker.

This procedure ensures that feedback will not occur even if the headset/belt pack is run at its maximum setting. It is also a measure of how the menu sign/post components are placed in relation to one another.

## Duplex and Standard Systems

<b>✓ Important Note</b>
For Duplex systems, the microphone at the menu sign must be located within four feet of the vehicle for duplex operation.

For Standard (half-duplex) systems, jumper J6 **must** be placed in the STD position.

The following procedures apply to both duplex and standard systems.

### Alert Tone Level

The alert tone level is the volume of the alert tone heard in the headset.

To set the alert tone level:

1. Turn the headset off and then on. (This sets the volume control to midrange.)

2. Have someone drive a vehicle up to the menu sign. When the vehicle is detected, you will hear the vehicle alert tone in the headset.
3. Adjust the HEADSET ALERT LEVEL control to provide a comfortable alert tone level in the headset (clockwise to increase; counterclockwise to decrease).

### Monitor Speaker Volume Levels

The monitor speaker volume levels are the levels for the various functions heard through the optional monitor speaker. All adjustment controls are located on the base station circuit board. Turn the controls clockwise to increase the volume and counterclockwise to decrease volume.

To set the monitor speaker volume levels:

1. Set the master MON VOLUME control to the midrange position.
2. With a vehicle detected at the menu sign (alert tone sounding), adjust the MON ALERT control so that the alert signal coming through the monitor speaker is at a suitable level.
3. Press and hold the headset **T**alk switch and speak into the headset microphone. Adjust the MON TALK control so that the talk audio coming through the monitor speaker is at a suitable level.
4. Press the headset **P**age switch and speak into the headset microphone. Adjust the MON PAGE control so that the page audio coming through the monitor speaker is at a suitable level.
5. While you listen to audio coming from the menu sign, adjust the MON IN control so that the menu sign audio coming through the monitor speaker is at a suitable level.

<b>✓ Important Note</b>
If any monitor functions are not desired by the customer, turn the related adjustment control fully counterclockwise to silence the function.

### Standard Systems Only

The following procedures apply only to standard systems.

<b>✓ Important Note</b>
For Standard (half-duplex) systems jumper J6 <b>must</b> be placed in the STD position.

### Listen Level (Menu Sign Microphone Sensitivity)

The listen level is the volume of the menu sign audio heard in the headset.

To set the listen level:

1. Turn the headset/belt pack off and then on. (This sets the volume control to midrange.)
2. Have someone drive a vehicle up to the menu sign. When the vehicle is detected, you will hear the vehicle alert tone in the headset/belt pack.
3. Press and release the headset **T**alk switch to cancel the alert tone and allow you to listen to the audio from the menu sign.
4. Adjust the MENU MIC SENS level control for the desired volume (clockwise to increase volume; counterclockwise to decrease.)

The Listen Level should now be properly adjusted. Because the headset/belt pack volume control was set at midrange, there will now be enough range (up/down) in the headset/belt pack volume control to allow operators to set the headset volume to a preferred level.

## Menu Sign Talk Volume Level

The menu sign talk volume level is the volume of the headset/belt pack audio heard at the menu sign.

To set the menu sign talk volume level:

1. Move the DAY/NIGHT switch on the base station to the DAY position.
2. Press and hold the headset/belt pack **T**alk switch and speak into the headset microphone.
3. Adjust the DAY menu sign audio level control for the desired audio level at the menu sign (clockwise to increase; counterclockwise to decrease.)
4. Move the DAY/NIGHT switch on the base station to the NIGHT position.
5. Press and hold the headset **T**alk switch and speak into the headset microphone.
6. Adjust the NIGHT menu sign audio level control so that the audio level at the menu sign is slightly lower than the DAY audio level setting (clockwise to increase; counterclockwise to decrease.)

# Circuit Board Jumpers, Adjustment Controls, Indicators and Switches

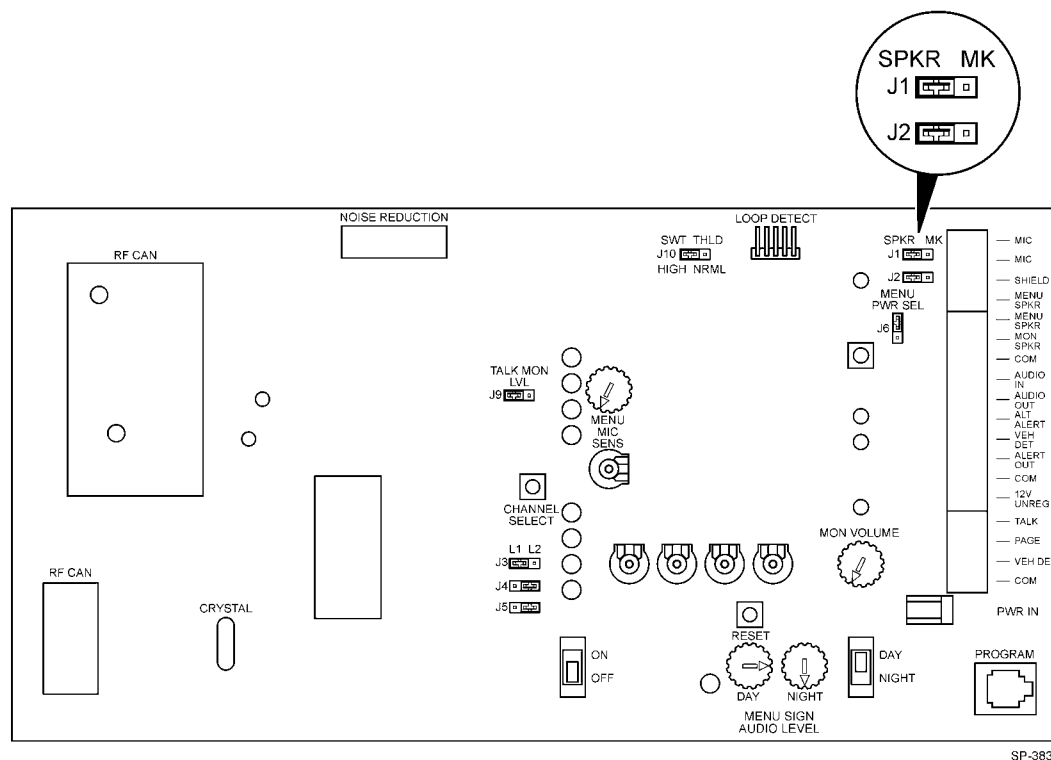

Figure 14. Base Station Circuit Board

## Jumpers

- J1 and J2 Set for the type of menu sign in the system. Jumper pins 1 and 2 on both jumpers for menu signs having a speaker only. Jumper pins 2 and 3 on both jumpers for menu signs having a speaker and a microphone.
- J3 Set to designate the number of the lane in the system. Jumper pins 1 and 2 to select lane 1. Jumper pins 2 and 3 to select lane 2.
- J4 Set for the type of vehicle detector in the system. Jumper pins 1 and 2 for an air switch detector. Jumper pins 2 and 3 for a loop/sodar detector.
- J5 Set to designate the type of communication operation. Jumper pins 2 and 3 for standard operation. Jumper pins 1 and 2 for duplex operation.
- J6 **MENU PWR SEL – STD or DPLX**  
**STD** – applies power to outbound speaker amplifiers only when the **TALK** switch is pressed. Note: for Standard (half-duplex) operation J6 **MUST** be placed in the **STD** position.  
**DPLX** – applies power to outbound speaker amplifiers constantly. This will reduce the click that is sometimes heard in duplex mode when the **TALK** button is pressed.
- J9 **TALK MON LVL**  
**REDUCE** – reduces the volume to the Monitor Speaker by 16dB while **TALK** is activated. This decreases the chance of feedback when a headset is operating near the Monitor Speaker in duplex mode.  
**FULL** – unreduced volume to monitor speaker in all modes.

### ✓ Important Note

This setting may cause feedback when a headset is operating near the monitor speaker in duplex mode.

- J10 **SWT THLD – HIGH or NRML**

**SWT THLD** refers to Switch Threshold. This jumper is used to change the dynamic gain threshold circuitry of the menu microphone. It should normally be set to NRML. Occasionally, the inbound audio volume will decrease when C1060 headsets are used in Talk Lock mode. Set jumper J10 to HIGH, in this case only.

**HIGH** – Jumper the left two pins ONLY if a decrease in inbound volume is noticed while C1060 headsets are being used in Talk Lock mode.

**NRML** – The Normal setting is used for all configurations except those mentioned in “HIGH.”

**✓ Important Note**

---

After changing any jumper setting(s), be sure to press the RESET SWITCH on the base station circuit board to “read” the change into the microprocessor.

### Adjustment Controls

<b>MENU MIC SENS</b>	Controls the volume of the menu sign audio heard in the headset.
<b>HEADSET ALERT LEVEL</b>	Controls the volume of the alert tone heard in the headset.
<b>DAY</b>	Controls the volume heard at the menu sign with the Day/Night switch in the Day position.
<b>NIGHT</b>	Controls the volume heard at the menu sign with the Day/Night switch in the Night position.
<b>MON VOLUME</b>	Master volume control for the following functions heard through the optional monitor speaker:
<b>MON ALERT</b>	Controls the alert tone level.
<b>MON IN</b>	Controls the audio level coming from the menu sign.
<b>MON PAGE</b>	Controls the page audio level coming from the headset/belt pack microphone.
<b>MON TALK</b>	Controls the talk audio level coming from the headset/belt pack microphone.

**✓ Important Note**

---

If any of the monitor functions are not desired by the customer, turn the appropriate adjustment control completely counterclockwise to silence that particular function.

### Indicators

<b>POWER</b>	Lights when power is applied to the base station.
<b>CHANNEL 1–8</b>	Lit LED indicates which channel is selected for base station operation.
<b>LOOP FAILURE</b>	(Optional) Flashes if vehicle loop fails.
<b>DETECTOR POWER</b>	(Optional) Lights if optional Loop Detector is functioning.
<b>NRM</b>	(Optional) Flashes slowly if optional noise reduction module is functioning.
<b>VEHICLE</b>	Lights when a vehicle is detected at the menu sign.
<b>TALK</b>	Lights during communication between headset/belt pack and menu sign.
<b>PAGE</b>	Lights during paging from headset/belt pack.

**Switches (etc.)**

ON/OFF Switch	Controls power to the base station.
DAY/NIGHT VOLUME Switch	Selects volume for day or night operation.
NRM ON/OFF	(Optional) Press to turn noise reduction module ON. Press to turn noise reduction module OFF.
CHANNEL SELECT Switch	Selects base station operating channel.
Programming Jack	For programming headsets/belt packs to the same channel as the base station.
RESET Switch	For programming new channel selection or jumper setting(s) into the microprocessor.

**Connectors:**

C5000 Terminal Strip	An extra 4 terminals at the bottom of the right-hand terminal block.
J7	Loop Detector Connector
J8	Noise Reduction Connector (under left half-cover)

## Finishing Up

1. Secure any loose wires.
2. Replace the cover on the base station module.
3. Check the operation of the system.
4. Check the operation of the auxiliary intercom.
5. Perform operator training, including the following functions:
  - Normal use and care of the system.
  - Use and care of the headset.
  - Battery replacement and recharging.
  - Operation of the base station module switches and controls.
  - Operation of optional Noise Reduction Module
  - Operation of Loop Detector

Refer to the Model C1060 Headset Intercom System Operating Instructions.

## Troubleshooting Audio Feedback

If audio feedback occurs, check the following and correct as necessary:

- Is the microphone audio cable shielded twisted pair – grounded at the inside end?
- Is the microphone audio wiring separately contained in its own cable, with no other “active” wires in the same cable?
- Are the speaker and microphone **at least** 24 inches apart?
- Is the outbound audio level too high?
- Is speaker audio being reflected back to the microphone from nearby surfaces?

## Technical Assistance

For communications equipment sales and service, contact your local 3M authorized intercom dealer. If special service assistance is needed, or for information on how to properly dispose of your non-functional C1060 rechargeable batteries, please call (800) 328-0033. For more information, visit the 3M Foodservice Web site: <http://www.3m.com/foodservice>

---

 **Warning**

**Always replace batteries, battery chargers and power supplies with 3M approved units acceptable for use in this system to avoid system function & safety concerns**

---

**3M**  
Commercial Care Division  
Food Services Business  
3M Center  
St. Paul, MN 55144-1000

Printed in U.S.A.  
©3M 2006 September  
70-0710-3649-8 Rev. E