

3M Communication Post Installation Instructions

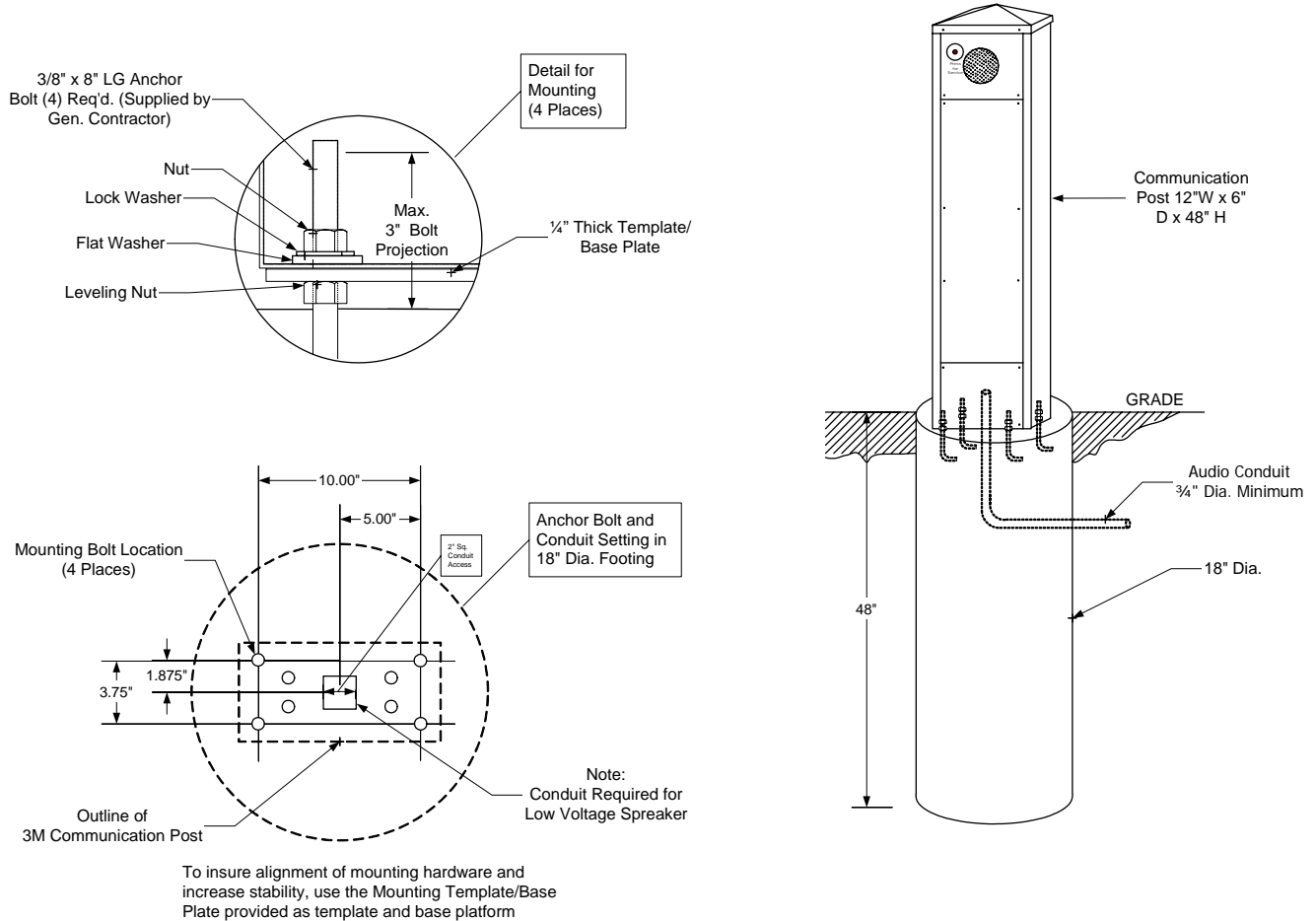

Communication Post Mounting Instructions:

Use the 1/4" thick Template/Base Plate to hold the 4 anchor bolts in place while the concrete sets. After the concrete has set, level the Template/Base Plate on the anchor bolts, then mount Communication Post on top of the Template/Base Plate.

3M Commercial Care Division

Food Service Business
3M Center
St. Paul, MN 55144-1000

©3M Company 2005 July

78-6912-0755-5 Rev A