

3M

Installation Instructions

3M Magnetic Loop Kit (Saw-in)

78-8016-9813-1

Note: A Special Applicator Gun, 3M PN: 78-6911-4656-3, is required to complete the installation of this kit.

Contents

| | Page |
|--|-------------|
| A. Introduction | 2 |
| B. Kit Contents | 2 |
| C. Sealant Storage | 2 |
| D. Electrical Rough-In Requirements | 3 |
| E. Installing the Magnetic Loop | 3 |
| 1. Marking the Saw Cut | 3 |
| 2. Cutting the Slot | 3 |
| 3. Cleaning the Slot | 3 |
| 4. Laying the Loop | 4 |
| 5. Surface Preparation/Temperature | 4 |
| 6. Application of 3M Sealant | 4 |
| F. Connecting the Loop Detector | 5 |
| G. Service Assistance | 5 |

Illustrations

| | |
|-------------------------------|---|
| Figure 1 Magnetic Loop Layout | 5 |
| Figure 2 Saw Cut Detail | 6 |

A. Introduction

These instructions explain how to install a 3M magnetic loop in an already surfaced driveway as part of a vehicle detection system used with a 3M drive-through intercom system. If the driveway has not yet been surfaced, you should use the 3M Prefab Loop Kit (78-8016-9901-4) that can be laid in before surfacing.

Each kit requires connection of the loop detector (containing the rest of the components required for the vehicle detection system) and connection of the detector to an intercom system such as a Wireless or D-series Intercom.

In addition to usual wiring tools, you will need:

- a concrete saw with a 3/16-inch wide blade
- a compressed air system (or bellows-type blower) to clean the slot
- a Manual Applicator Gun, 59cm., 3M PN: 78-6911-4656-3
- several wooden wedges or foam type backer rod to hold the wire in the slots

The following steps summarize the more complete instructions that follow.

1. Mark the loop and lead-in saw cuts on the driveway surface.
2. Cut the slots for the loop and lead-in.
3. Clean the slot.
4. Lay the loop in the slot.
5. Twist the lead-in pair together and lay them through the slot and conduit into the menu sign.
6. Fill the slot with sealant.

B. Kit Contents - 78-8016-9813-1, 3M Magnetic Loop Kit

Check that in addition to these instructions, the 3M Magnetic Loop Kit contains 100 feet of 14 AWG wire, type MTW, and two 1-liter Ply pak cartridges of 3M Detector Loop Sealant.

C. Sealant Storage

Store the sealant in a cool place, away from heat and acids.

For maximum shelf life, store the sealant at 80° Fahrenheit - or below.

Keep the sealant in a well-ventilated area.

Keep the sealant away from children.

Keep the sealant out of direct sunlight.

D. Electrical Rough-in Requirements

The following rough-in (done by the menu sign construction electrician) is required for proper installation of the magnetic loop:

1. A minimum of a 3/4-inch underground conduit from the menu sign to inside of the building. This conduit is for the speaker/detect cable that will provide the OSM (Outside Speaker/Mic) audio wiring and the magnetic loop wiring to the detector inside the building.
2. A 1/2-inch non-metallic conduit from inside the speaker post, stubbed off at curbside, about **one Inch below the driveway level**, in front of the speaker post. Naturally, this conduit must be installed before the speaker post

base is poured, and the electrician must lay a block of wood across the conduit to prevent its being plugged by surfacing material.

E. Installing the Magnetic Loop

The following instructions describe how to cut the pavement, install the magnetic loop, and then seal the loop.

Note

Do not cut a driveway surface that **is less than three inches thick**. Thin driveways will eventually crack and ruin the loop. If the driveway surface is less than three inches thick, the owner must replace the section in front of the menu sign with a concrete pad that is at least five inches thick for proper installation of the vehicle detector loop.

1. Marking the Saw Cut (See figures 1 and 2)

- a. Lay out and mark an 18 inch by 54 inch rectangle. As shown in figure 1, position the rectangle with the **short side** parallel to and directly in front of the speaker post, approximately one foot from the curb. Locate the rectangle so that it will be positioned beneath the driver's feet when the car stops with the driver directly opposite the microphone in the speaker post. There must be no metal pipe, reinforcing bars, or conduit inside of or within one foot of the rectangle.
- b. Mark the 45° corner cuts, about six inches from each corner as shown in figure 1.
- c. Mark a double-width, 3/8-inch feed-in slot from the corner nearest the conduit feeding into the speaker post. If there is no feed-in conduit, you must cut the slot to where the lead-in can enter the speaker post.
- d. Mark a 45° exit slot cut from the short side of the rectangle to the feed-in cut. See figure 1.

2. Cutting the Slot

You will need a special concrete saw with a blade that cuts a 3/16-inch wide groove. Such saws are available for rent in most larger cities. Set the saw for a 1-1/2-inch cut depth. Make all cuts overlap as shown in figure 2. Proceed as follows:

- a. Cut the four rectangle sides. Do not connect the rectangle corners as shown in figure 2.
- b. Cut the four 45° corners.
- c. Cut a double-width, 3/8-inch lead-in slot from the conduit feed-in corner to the conduit. Use a 3/8-inch blade or cut two parallel 3/16-inch slots, removing any uncut material between the slots.
- d. Cut a 45° exit cut to the lead-in slot as shown in figure 1.

Note

If you are installing a new loop above an existing loop, be sure that one of the saw cuts completely severs the wires of the existing loop.

3. Cleaning the Slot

Use an air hose or bellows-type blower to clean all dust and debris from the slots.

4. Laying the Loop

- a. Measure or lay out sufficient loop wire to reach from inside the menu sign, through the conduit and lead-in slot, to the rectangle.
- b. Entering the rectangle at the lead-in slot corner as shown in figure 1, lay the wire around the rectangle, using the 45° corner slots. Use a wooden paint stirrer or other blunt instrument to push the wire to the bottom of the slot.
- c. Repeat the lay-in two more times for a total of five turns, pushing each loop of wire down into the slot.

- d. Use pieces of a wooden paint stirrer or other wedges to temporarily hold the wire loops in the slot.
- e. Route the exit wire to the lead-in slot, through the angle, cut as shown in figure 1.
- f. Twist the exit and entry wires tightly together (six turns per foot) as shown in figure 1 and then cut off the excess wire.
- g. Lay the twisted pair in the lead-in slot and pull it through the conduit into the menu sign.

5. Surface Preparation Temperature (Also see the instructions on the sealant cartridge.)

The saw cut should be free of dust, debris and water.

The surface temperature of the saw cut/loop should not exceed 100° F or be less than 40° F.

6. Application of 3M Detector Loop Sealant (Also see the instructions on the sealant cartridge.)

WARNING - IMPORTANT PRECAUTIONS

WEAR GLOVES WHEN HANDLING THE SEALANT AND AVOID CONTACT OF THE SEALANT WITH SKIN, EYES AND CLOTHING.

WASH THE GLOVES BEFORE REUSING THEM.

IF CONTACT OCCURS:

SKIN CONTACT - FLUSH IMMEDIATELY WITH WATER.

EYE CONTACT - FLUSH IMMEDIATELY AND CONTINUOUSLY WITH WATER AND CONTACT A PHYSICIAN AS SOON AS POSSIBLE.

CLOTHING CONTACT - LAUNDRER CLOTHES BEFORE REUSING THEM.

- a. Depress the plunger release on the Applicator Gun, and pull the plunger all the way out. Note: If the trigger is depressed while trying to pull the plunger out - the plunger will not move.
- b. Remove the gun end cap.
- c. Place the ply pack sealant into the applicator gun. Make sure that the ply pack sealant is inserted all the way into the gun barrel.
- d. Place the nozzle (provided with the sealant) onto the end of the gun barrel. Place the end cap over the nozzle and tighten.

| Caution |
|---|
| Puncture points at interior base of the applicator gun nozzle are sharp. Touching the puncture points may result in accidents and/or injuries. Avoid contact with the puncture points while installing sealant and while operating the applicator gun. |

Note: Do not apply the sealant during a rainfall.

The sealant dries tack-free in 24 hours but may be walked/driven on almost immediately after application.

F. Connecting the Loop Detector

Install the loop detector following the instructions provided with that unit. To connect the loop to the detector, you will need a twisted pair, 18-gauge cable from the menu sign to inside the building. The 3M Three Pair Combination Duplex Cable (78-8095-0180-8) can fill this requirement and provide two additional wire pairs for the speaker and mic connections.

Connections to the loop wiring must be soldered connections.

G. Service Assistance

If you have any questions or require assistance in installing this kit, contact:

3M Food Services Trade Department Technical Service
3M Center
St. Paul, MN 55144-1000
1-800-328-0033

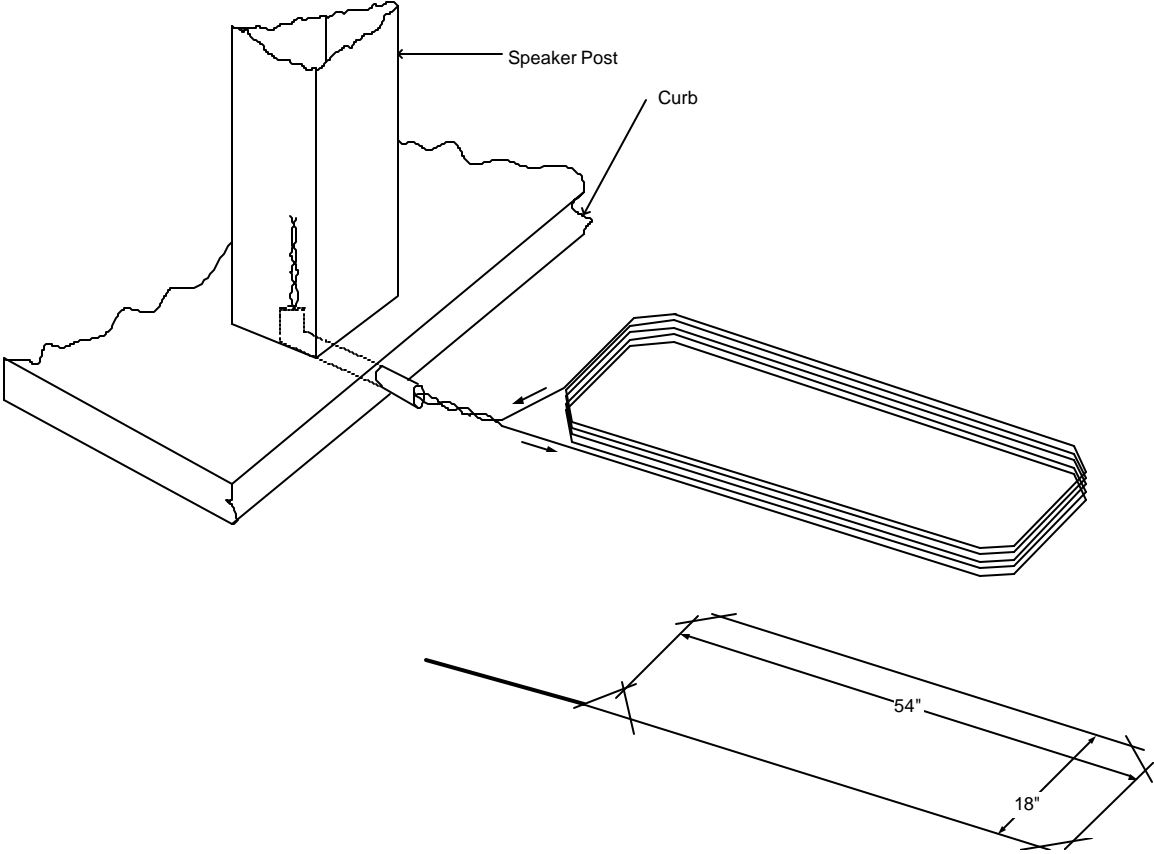
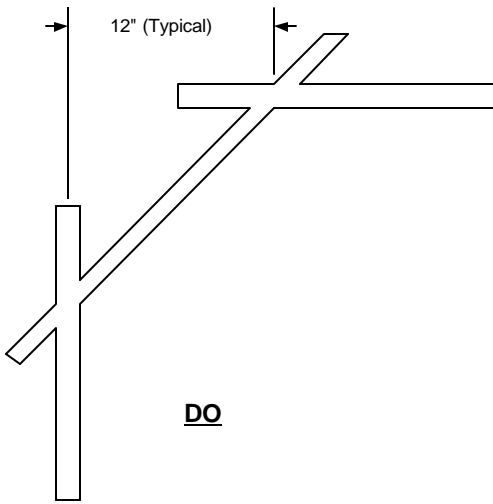
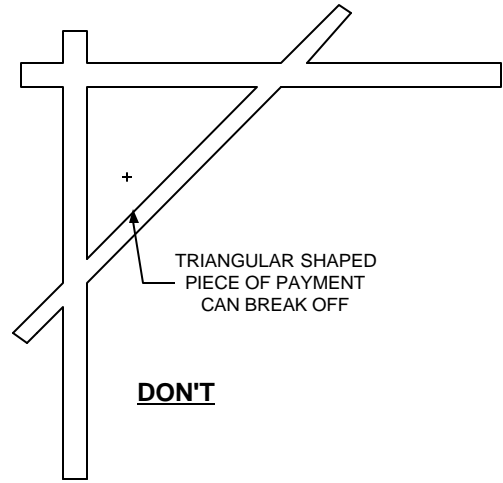

Figure 1 Magnetic Loop Layout



DO



DON'T

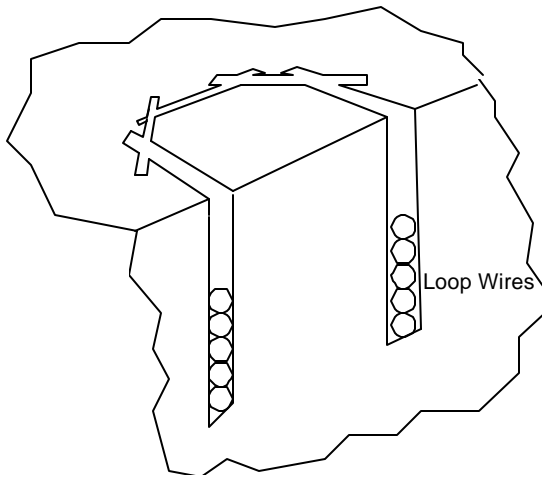

Figure 2 Saw Cut Detail