

3M

WIRELESS INTERCOM SYSTEM

Service Information

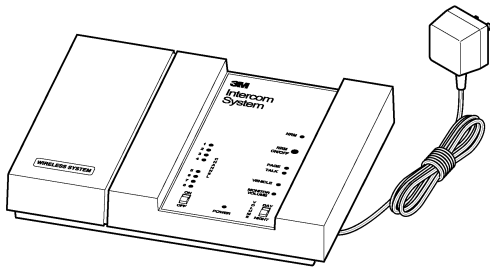

Base Station

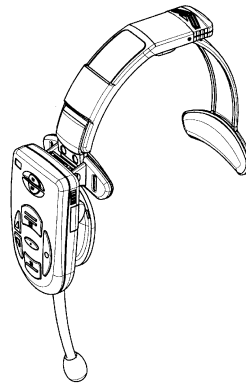

C960 Headset

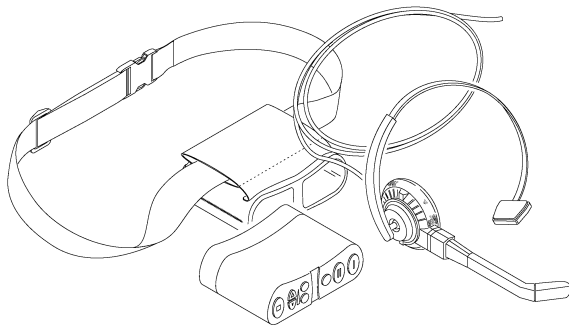

Headset & Belt Pack



C1060 Headset

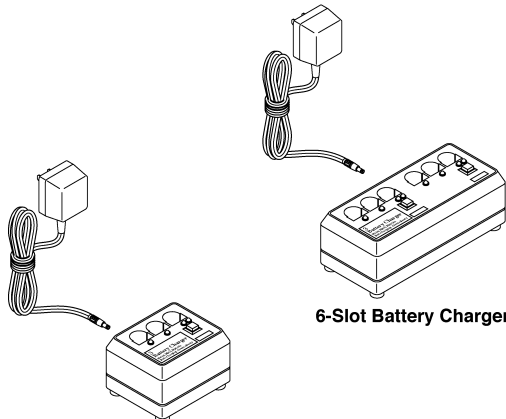

3-Slot Battery Charger

6-Slot Battery Charger

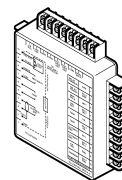

Interconnect Module

SP-290A

3M

Food Services Trade Department
3M Center
St. Paul, MN 55144-1000

Printed in U.S.A
©3M 2003 March
70-0710-3745-4

Section 1. Operation and Diagrams

Introduction	1-1
System Components	1-1
Base Station.....	1-1
Headset.....	1-1
Battery Charger	1-1
Speaker and Microphone Assemblies	1-1
Interconnect Module	1-1
Cross-Lane Module	1-1
Vehicle Alert System	1-1
System Configurations	1-1
Single-Lane Standard Communication System.....	1-1
Dual-Lane Standard Communication System	1-1
Single-Lane Duplex Communication System	1-2
Dual-Lane Duplex Communication System.....	1-2
Cross-Lane Communication System.....	1-2
Operating Theory	1-2
Processing Vehicle Alert Signals	1-2
Transmitting and Receiving	1-2
Talk/Listen Communication.....	1-3
Talk Lock Mode.....	1-3
Page Mode.....	1-3
Page Monitor Mode.....	1-4
Cross-Lane Talk/Listen Mode.....	1-4
Monitor Amplifier and Speaker	1-4
Headset Components.....	1-4
Rechargeable Battery	1-4
Base Station.....	1-5
DC Power	1-5
Talk/Page Input	1-5
Vehicle Detector Input	1-5
Menu Mic Input.....	1-6
Base Station Configuration Jumpers and Switches.....	1-6
Base Station and External Components Diagram	1-9
Interconnect Module	1-11
On/Off DC.....	1-11
Menu Microphone Signal Control.....	1-11
Menu Speaker Audio Control	1-11
Monitor Speaker Audio Control.....	1-11

Vehicle Detector Signal DC 1-11
Interconnect Module Diagram..... 1-13

Section 2. Installation Instructions

- C860/C960 Installation Instructions
- C1060 Installation Instructions

Section 3. Replacement Parts and Service

- Technical Service
 - Base Station Assembly and Interconnect Module
 - C860/C960 - 3-Slot Battery Charger Assembly
 - C860/C960 - 6-Slot Battery Charger Assembly
- C860 Replacement Parts and Service..... 3-1
- C960 Replacement Parts and Service
 - Headset Assembly 3-3
 - Replacing the Headset Speaker 3-5
 - Replacing the Mic Boom Assembly..... 3-8
 - Replacing the Battery Release Button Spring 3-9
- C1025 Replacement Parts and Service..... 3-11

Section 4. Operating Instructions

- Model C860 Operating Instructions
- Model C960 Operating Instructions
- Model C1025 Operating Instructions
- Model C1060 Operating Instructions

Section 5. Installation Instructions for Accessory Equipment

- Model A121 Noise Reduction Module, External, 78-9236-6403-7
- Model A125 Noise Reduction Module, Internal, 78-9236-6453-2
- Models A200 and A201 Loop Detector
- Model A300 Audio Greeter
- Model A300 Operating Instructions
- Model A300 Wall Placard
- 5-Inch Duplex Speaker Assembly, 78-6911-4411-3
- Automatic Level Control Module, 78-6911-4402-2
- Cross-Lane Module, 78-6911-4396-6
- Duplex Menu Cable, 78-8095-0180-8
- Five Inch Speaker and Mic Assembly, 78-6911-1545-1
- Microphone, Duplex System With Bracket, 78-6911-4400-6
- Microphone Duplex System With Foam Housing, 78-6911-4476-6
- Signal Enhancer, 78-9236-6517-4

Introduction

The 3M Wireless Intercom System is designed for high reliability, compactness, and ease of service. It is designed to provide two-way, radio-frequency audio communication in quick service drive-through restaurants and convenience stores.

The system can be programmed to operate on any one of 16 different channels to provide high-quality audio performance and reduce the possibility of interference between neighboring wireless systems.

System Components

The number of components in a system varies depending on the system configuration. However, the base station, headset, and battery charger are common to all system configurations.

Base Station

The wall-mounted base station contains logic and analog circuits and related system controls, a receiver to receive signals transmitted *from* the headsets, and a transmitter to transmit signals *to* the headsets.

Headset

The headset is a wireless, battery-powered, two-way radio used by the operator to communicate with menu sign customers and with other store personnel who are wearing headsets. The microphone and earpiece enable the operator to transmit and receive spoken communication and alert tones.

Some models of the headset assembly have field-replaceable components. These components are detailed in Section 3 of this manual (Replacement Parts and Service).

Battery Charger

The battery charger charges headset batteries in approximately 1.5 to 3 hours. The charger is available in 3-slot and 6-slot versions.

The battery charger has no field-replaceable components other than the power supply.

Speaker and Microphone Assemblies

Standard (Non-Duplex) Systems

The 5-Inch Speaker and Mic Assembly is recommended for use in standard communication systems. It consists of a 5-inch, weather-resistant,

eight-ohm cone speaker plus a special weather-resistant dynamic microphone. It also includes a mounting bracket for easy mounting in menu signs, speaker posts and other applications. Using this separate speaker and microphone ensures maximum sound quality.

Duplex Systems

The 3.5-Inch Duplex Microphone and 5-Inch Duplex Speaker Assembly are recommended for use in duplex communication systems. The microphone is mounted on a foam housing, which can be cut to the required size. The speaker is mounted in a metal housing.

Interconnect Module

This optional module provides a convenient connection point for equipment such as speakers, microphones, vehicle detectors, and auxiliary intercoms.

Cross-Lane Module

This module is a required component for dual-lane duplex cross-lane communication systems. It enables a single headset to operate two base stations.

Vehicle Alert System

The Wireless Intercom System is compatible with all 3M vehicle detectors and those of most other manufacturers.

System Configurations

The system can be configured in one of five ways depending on the number of menu signs at the facility and the type of communication desired.

Single-Lane Standard Communication System

This system provides standard communication (talk/listen) for facilities that have one menu sign. It consists of one base station and one or more headsets and battery chargers.

Dual-Lane Standard Communication System

This system provides standard communication (talk/listen) for facilities that have two menu signs. It consists of two independent systems - one dedicated to menu sign 1 and the other dedicated to menu sign 2. The headsets are programmed to work with one system or the other and are labeled accordingly (1 or 2).

Single-Lane Duplex Communication System

This system provides duplex communication (simultaneous talk/listen) for facilities that have one menu sign. It consists of one base station and one or more headsets and battery chargers.

Dual-Lane Duplex Communication System

This system provides duplex communication (simultaneous talk/listen) for facilities that have two menu signs. It consists of two base stations and two or more headsets and battery chargers.

Cross-Lane Communication System

This system provides duplex communication (simultaneous talk/listen) for facilities that have two menu signs. It consists of two duplex systems that are connected to a cross-lane module. The headsets are programmed for both lane 1 and lane 2.

During off-peak hours, the cross-lane module is turned on to link the two systems and enable one operator to talk to customers at menu sign 1 or menu sign 2 or with other headset operators.

During peak hours, the cross-lane module is turned off to separate the systems. With the cross-lane module off, one system is dedicated to menu sign 1 and the other to menu sign 2. Menu sign 1 operators can talk to customers at menu sign 1 or with other headset operators. Menu sign 2 operators can talk to customers at menu sign 2 or with other headset operators.

Operating Theory

The 3M Wireless Intercom System has two basic functions. First, it processes vehicle alert signals that are supplied by a hard-wired vehicle detection system. Second, it transmits and receives radio signals to provide the following communication:

- Talk/listen communication
- Page communication

Processing Vehicle Alert Signals

The vehicle alert system provides a signal to the base station to indicate a customer is present at the menu sign.

There are two types of vehicle detectors. *Presence detectors* (such as magnetic loops) provide a signal for as long as a vehicle is present at the detector. *Pulse detectors*, such as air hoses, provide only a momentary signal—signalling vehicle arrival with no indication of whether or not the vehicle remains at the detector station.

- If a presence detector is used, menu sign audio is turned off automatically when the vehicle leaves.
- If a pulse detector is used, menu sign audio is silenced by pressing and releasing a headset page switch.

When a vehicle detection signal is presented to the base station, the base station broadcasts a repeating alert tone to all headsets. The alert tone continues until the talk switch [on an active headset] is pressed.

Transmitting and Receiving

The transmitting and receiving functions are accomplished by two separate sets of radio transmitters and receivers. One set is located in the headset and the other in the base station.

The headset receives microphone audio signals from the base station on *frequency B* and transmits both audio signals and control tones on *frequency A*. The control tones are above the audible range, and function to turn the menu sign speaker's amplifier ON during the talk operation. The base station receiver is also always ON when the base station is powered. Similarly, when the headset is powered, the headset receiver is always ON to enable the listen mode. The headset modulator turns ON only when a talk or page switch is pressed.

The transmitter in the base station is always transmitting a “no signal” transmitter carrier, even when there is no microphone audio from the menu sign or headset operator being broadcast. This “no signal” carrier is continually broadcast to and received by all headset receivers. It serves to block out other radio-frequency signals or noises from headset receivers.

In standard communication systems, the output from the headset receiver is muted when the headset transmitter is ON. This provides standard (non-duplex) communication (talk *or* listen).

In duplex communication systems, the output from the headset receiver is enabled (not muted) when the headset transmitter is ON. This provides duplex communication (*simultaneous* talk *and* listen).

The two sets of transmitters and receivers work together to provide audio communication between the customer at the menu sign and the headset operators inside the drive-through restaurant *or* between two or more headset operators.

All audio transmitted by a headset during talk operation is heard by:

- Menu sign customers.
- Personnel wearing active headsets.
- People near the optional monitor speaker.

All audio from the menu sign is heard by:

- Personnel wearing headsets that are operating in the talk/listen mode.
- People near the optional monitor speaker.

Talk/Listen Communication

Headset to Menu Sign

After the vehicle detection signal is presented to the base station, the base station broadcasts a repeating alert tone to all active headsets.

The headset operator presses and holds the talk button to acknowledge the customer at the menu sign and cancel the alert tone. When the headset operator speaks into the microphone, the headset generates a talk control tone and adds it to the microphone audio. The microphone audio and talk control tone are then transmitted to the base station. The talk control tone turns the base station amplifier ON, which drives the menu speaker enabling the customer to hear the audio.

When the base station receives the microphone audio signal, it re-transmits it to all headset receivers. The same microphone audio signal is also routed to the monitor speaker amplifier if that option has been selected.

✔ Note

The menu sign audio is not turned ON unless the base station receives a talk control tone from the headset. However, the the monitor amplifier is always turned ON.

Menu Sign to Headset

When the customer at the menu sign speaks, audio is detected by a microphone and sent through wire to the transmitter and the monitor amplifier in the base station.

The transmitter transmits the microphone audio to all headset receivers. The monitor amplifier routes the same microphone audio through wire to the optional monitor speaker.

✔ Note

Personnel wearing headsets that are set to monitor only page communications will not hear talk communications.

Talk Lock Mode

The talk lock mode is used to operate “hands free.” In this mode, the headset automatically switches from standby to talk/listen when a customer is detected at the menu sign. The headset automatically switches back to standby when the customer leaves the menu sign. This mode is only available with duplex system configurations.

Page Mode

When the headset page button is pressed, system operation is identical to *talk* operation except for two things:

- The *talk control tone* is not broadcast, so the menu sign amplifier is not turned on, muting menu sign audio.
- A *page control tone* is sent from the headset. The transmitter rebroadcasts this tone to turn ON any headsets that are in the page monitor mode. Any audio detected by the headset microphone is

transmitted to the base station where it is received, transmitted to other headsets and sent to the monitor speaker amplifier.

Page Monitor Mode

The page monitor mode allows headset operators to hear only page communication. In the page monitor mode, talk audio output to the headset is muted. Only internal page communication is heard because the headset earphone amplifier is turned ON only when it receives a *page control tone*. Talk transmissions from other headsets or audio from the menu sign are not heard.

Cross-Lane Talk/Listen Mode

The cross-lane talk/listen mode is available only in a dual-lane duplex cross-lane system. The cross-lane module in this system enables the menu sign operator to selectively communicate (talk and listen) to customers in *either* lane 1 *or* lane 2.

With the T1 (Talk Lane 1) switch pressed, the headset transmitter/receiver switches to the lane 1 channel frequencies, enabling the lane 1 base station and lane 1 communications.

With the T2 (Talk Lane 2) switch pressed, the headset transmitter/receiver switches to the lane 2 channel frequencies, enabling the lane 2 base station and lane 2 communications.

Monitor Amplifier and Speaker

A one-watt, single-ended monitor amplifier in the base station powers [an optional] speaker which is capable of reproducing the following signals:

- Talk audio (communications *to* the menu speaker)
- Listen audio (communication *from* the menu speaker)
- Page audio (internal store communications)

- Vehicle alert tone

Separate volume controls adjust the level of each signal to achieve the desired signal balance. In addition, there is a master volume control which adjusts the overall volume of the monitor speaker.

Headset Components

✔ Note

The receiver/transmitter and logic circuitry contained in the headset housing is both proprietary and non-field repairable.

Some models of the headset assembly have several field-replaceable components. These components are detailed in Section 3 of this manual (Replacement Parts and Service).

The major components are as follows:

- Rechargeable Battery
- Headband
- Microphone Boom Assembly
- Speaker Assembly

Rechargeable Battery

The nickel metal hydride or lithium-ion battery provides DC power for the headset circuitry.

Base Station

✔ Note

Receiver/transmitter and logic circuitry contained in the base station is both proprietary and non-field repairable. For this reason, the accompanying base station diagram provides no circuit component detail. Only those details that assist fault isolation (such as connections, configuration jumpers, audio control circuits, replaceable components and input/output functions) are shown.

DC Power

DC power for the base station circuits and external components is provided as follows:

A self-contained DC power transformer, connected to 120VAC, provides unregulated +12VDC to the base station power input jack. The +12VDC is turned on or off by a slide switch located on the front of the base station. The unregulated +DC is routed through a protective polyswitch (circuit breaker) to circuit components and a voltage regulator (called power supply in the diagram). If an overcurrent condition causes the polyswitch to open, it automatically resets after power is removed.

The unregulated +12VDC is used by the vehicle detector to provide a +DC vehicle detect signal to the base station vehicle detect circuits. If an interconnect module is used in the system, unregulated +DC is provided to energize the interconnect module relays.

Talk/Page Input

Talk and page voice communications transmitted from the headset are received along with their accompanying “talk” or “page” control tones. Received talk communications are routed by the RCVR & RCVR LOGIC as follows:

- To the menu sign speaker amplifier via the DAY/NIGHT volume controls and DAY/NIGHT switch, through the amplifier to the menu sign
- To the monitor speaker amplifier via the MON TALK volume control, through the amplifier and the Master Monitor Volume control to the monitor speaker

- Through the transmit amplifier to the TXMT & TXMT LOGIC for transmission to all headset receivers and to output connector AUDIO OUT for use in cross-lane applications

Received page communications are routed by the RCVR & RCVR LOGIC as follows:

- To the monitor speaker amplifier via the MON PAGE volume control, through the amplifier and the Master Monitor Volume control to the monitor speaker
- Through the transmit amplifier to the TXMT & TXMT LOGIC for transmission to all headset receivers, and to output connector AUDIO OUT for use in cross-lane applications

Vehicle Detector Input

Upon detection of a vehicle, the vehicle detector signal will be a steady DC or a short-duration DC pulse depending on whether the vehicle detector is a “presence” or “pulse” type detector. Upon receipt of the vehicle detect signal, the VEHICLE DETECT LOGIC circuit emits alert tones. These alert tones are routed as follows:

- To the monitor speaker amplifier via the MON ALERT volume control, through the monitor speaker amplifier and the Master Monitor volume control to the monitor speaker
- To the transmit amplifier via the Headset Alert Level control, through the amplifier to the TXMT & TXMT LOGIC for transmission to all headset receivers
- To output connector ALERT OUT for use in cross-lane applications

✔ Note

The vehicle detect PULSE/PRESENCE jumper J4 must be set appropriately and its setting programmed into the base station logic for correct vehicle detection and alert tones to occur. For further explanation of vehicle detect alert tones, refer to the paragraphs titled *Vehicle Alert System* and *Vehicle Detector Input* in this section.

Menu Mic Input

Audio from the menu sign may come from one of two sources: a combination speaker/microphone (the MENU SIGN SPEAKER) or a separate dynamic microphone (the MENU MIC). The MIC/SPKR jumpers J1 and J2 must be set accordingly; both must be set to the MIC position if a separate outside mic is used, to the SPKR position if a combination outside speaker/mic (OSM) is used. Depending on jumper positions, mic input is routed to the mic amplifier, through the amplifier and its Menu Mic Sensitivity control and then:

- To the monitor speaker amplifier via the MON IN volume control, through the monitor speaker amplifier and the Master Monitor volume control to the monitor speaker
- Through the transmit amplifier to the TXMT & TXMT LOGIC for transmission to all headset receivers, and to output connector pin 9 for use in cross-lane applications

Base Station Configuration Jumpers and Switches

Configuration Jumpers

Jumpers J1 and J2 are used to configure the base station for use with either a separate outside microphone or a combination outside speaker/mic (OSM). Unlike jumpers J3, J4 and J5 which affect logic input levels, jumpers J1 and J2 simply switch the microphone amplifier inputs to either the microphone or OSM. Set both jumpers to jumper pins 2 and 3 for use with a separate outside mic, or to jumper pins 1 and 2 for a combination speaker/mic (OSM).

Jumper J3 is used to configure the base station for use in a cross-lane, dual-lane communications system. In such a system, one base station must be set for lane 1 frequency communications, the other base station must be set for lane 2 frequency communications. Jumper J3 pins 1 and 2 (forcing the related logic input high) for lane 1 configuration. Jumper J3 pins 2 and 3

(forcing the related logic input low) for lane 2 configuration. Whenever any jumper is changed, you must press the base station RESET switch to program the new jumper setting into the base station microprocessor.

✍ Note

It may also be necessary to re-program system headsets, depending on system configuration. Refer to the Installation Instructions for more information.

Jumper J4 is used to configure the base station for use with either a presence type vehicle detector or a pulse type vehicle detector. Jumper J4 pins 1 and 2 (forcing the related logic input high) for a presence type detector. Jumper J4 pins 2 and 3 (forcing the related logic input low) for a pulse type detector. Whenever jumper J4 is changed, you must press the base station RESET switch to program the new jumper setting into the base station microprocessor.

Jumpers J5 and J6 are used to configure the base station so that it can in turn, program the headsets for standard (talk, then listen, then talk etc.) communications or for duplex (simultaneous talk and listen) communications. During standard communications, headset receiver output is muted during talk transmissions. During duplex communications, headset receiver output is not muted during talk transmissions. The headset receiver mute/not mute (standard/duplex) command is sent to the headset logic during headset programming—determined by the jumper J5 setting. Whenever any Jumper is changed, you must press the base station RESET switch to program the new jumper setting into the base station microprocessor.

✍ Note

When any jumper is changed, you must also reprogram the system headsets. Refer to the Installation Instructions for more information.

Configuration Switches

RESET SWITCH: Very briefly, actuation of the RESET SWITCH clears logic inputs of their established levels and latches the logic inputs at their new levels.

CHANNEL SELECT SWITCH: The Wireless Intercom System is capable of operating on eight different channels for each of two lanes. This provides a total of 16 operating channels since each system may be designated as a lane 1 or lane 2 system. Each operating channel is comprised of a “set” of two frequencies, one for receiving, one for transmitting. The channel frequencies are preprogrammed in both the base station and headset microprocessors. Each actuation of the CHANNEL SELECT switch prompts the base station microprocessor to advance to the next available channel. After a new channel is selected, you must reprogram all system headsets to the new channel. For more information on channel selection and reprogrammng, refer to the Installation Instructions.

(Blank Page)

Base Station and External Components Diagram

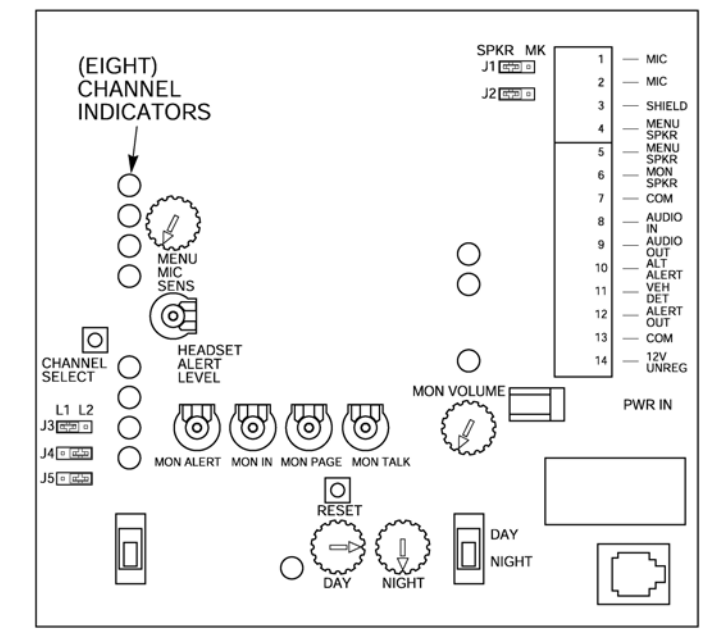
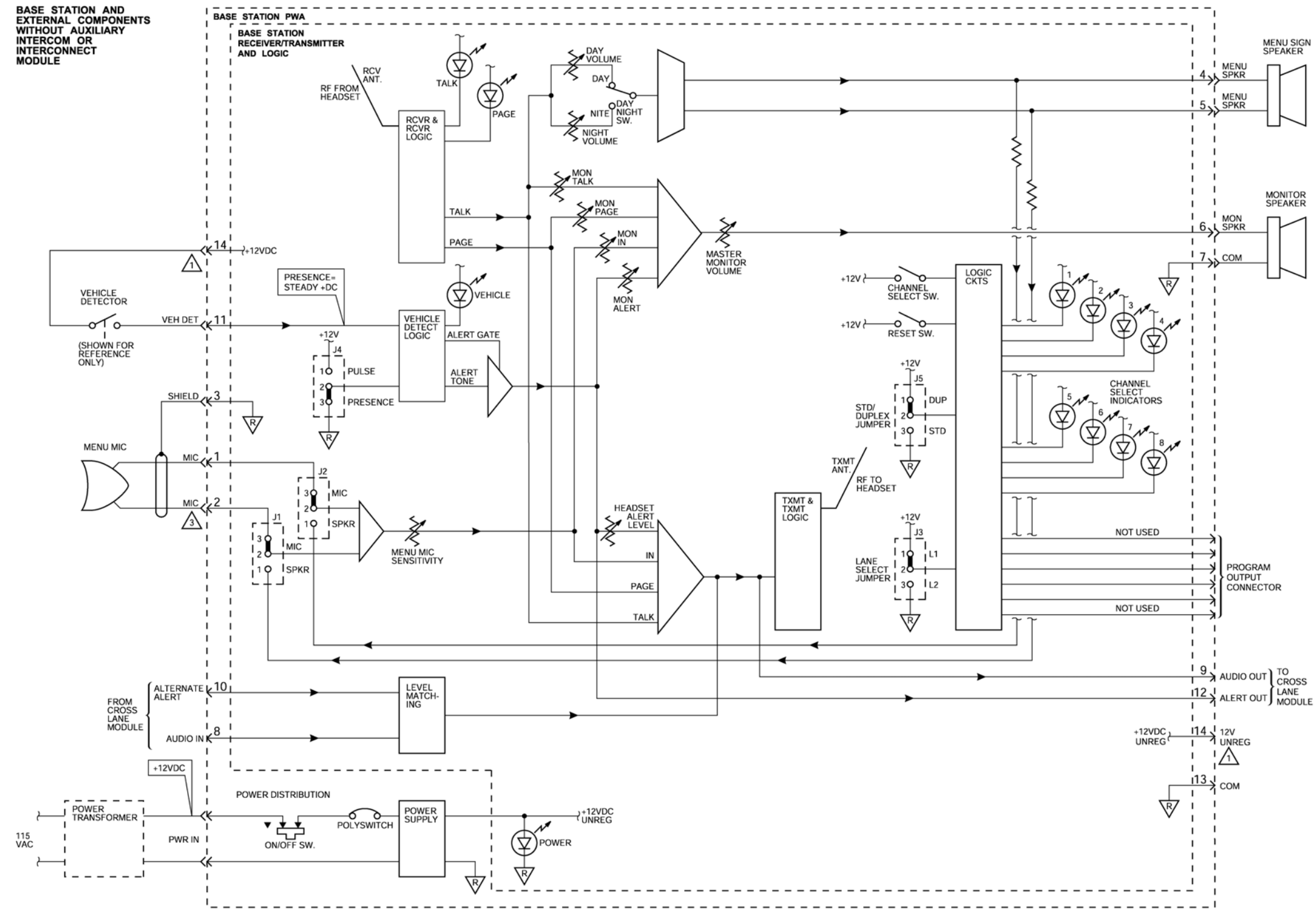

BASE STATION CIRCUIT BOARD

- NOTES:
- ① CONNECTION SHOWN TWICE FOR CLARITY
 - ② JUMPERS SHOWN IN MICROPHONE (J1/J2), PRESENCE (J4), DUPLEX (J5), LANE 1 (J3) SETTINGS
 - ③ ALL MICROPHONE WIRING SHOULD BE SHIELDED, TWISTED PAIR

SP-533A

(Blank Page)

Interconnect Module

An interconnect module is needed when a Headset Intercom System includes an auxiliary intercom to provide continued communications when the primary intercom needs service.

The auxiliary intercom may be a conventional, hard-wired intercom or it may be a second base station.

External system components (speakers, microphone, vehicle detector) connect to interconnect module connector J302. Base station inputs and outputs (power, common, menu mic, menu speaker, vehicle detector) connect to interconnect module connector J303. Auxiliary intercom (or second base station) inputs and outputs connect to interconnect module connector J301.

On/Off DC

In the interconnect module schematic diagram, the interconnect module is shown in its “off” state, with relays de-energized.

On/Off control of the interconnect module is provided by (the presence or absence of) +12VDC from the (primary) base station. With base station +12VDC present (via J303 pins 1 and 2), relays K301, K302 and K303 energize to switch microphone, speaker and vehicle detect signals to/from the base station. If the base station-provided DC is not present (base station turned off), relays K301, K302 and K303 de-energize to switch the same signals to/from the auxiliary intercom.

Menu Microphone Signal Control

Relay contacts K301-A and K301-B control distribution of the menu mic signal(s). With relay K301 energized, the menu mic is connected to the base station inputs. With Relay K301 de-energized, the menu mic is connected to the auxiliary intercom.

Menu Speaker Audio Control

Relay contacts K302-A and K302-B control distribution of the menu speaker audio. With relay K302 energized, the menu speaker is connected to the base station. With relay K302 de-energized, the menu speaker is connected to the auxiliary intercom.

Monitor Speaker Audio Control

Relay contacts K303-B control distribution of monitor speaker audio. With relay K303 energized, the drive side of the monitor speaker is connected to the monitor speaker output of the base station. With relay K303 de-energized, the drive side of the monitor speaker is connected to the monitor speaker output of the auxiliary intercom. Monitor speaker common is not switched.

Vehicle Detector Signal DC

While the vehicle detector is powered separately (if it is a “presence” type detector), vehicle detector signal DC is always provided by both the base station and the auxiliary intercom. This vehicle detector signal DC is available at interconnect module connector J302-9.

A vehicle detector signal DC of +12VDC is provided by the base station at J303 pins 9 and 10. A vehicle detector signal DC of +18VDC is provided by the auxiliary intercom at J301 pins 1 and 7.

If both the auxiliary intercom and the base station are ON, the vehicle detector signal will always be +18VDC because the auxiliary intercom’s +18VDC will take precedence over the +12VDC supplied by the base station. (Isolation of the two DC sources is provided by interconnect module diodes D301 and D303.) If only the base station is ON, the vehicle detector signal DC will be +12VDC.

(Blank Page)

INTERCONNECT MODULE (SHOWN IN AUXILIARY SYSTEM MODE)

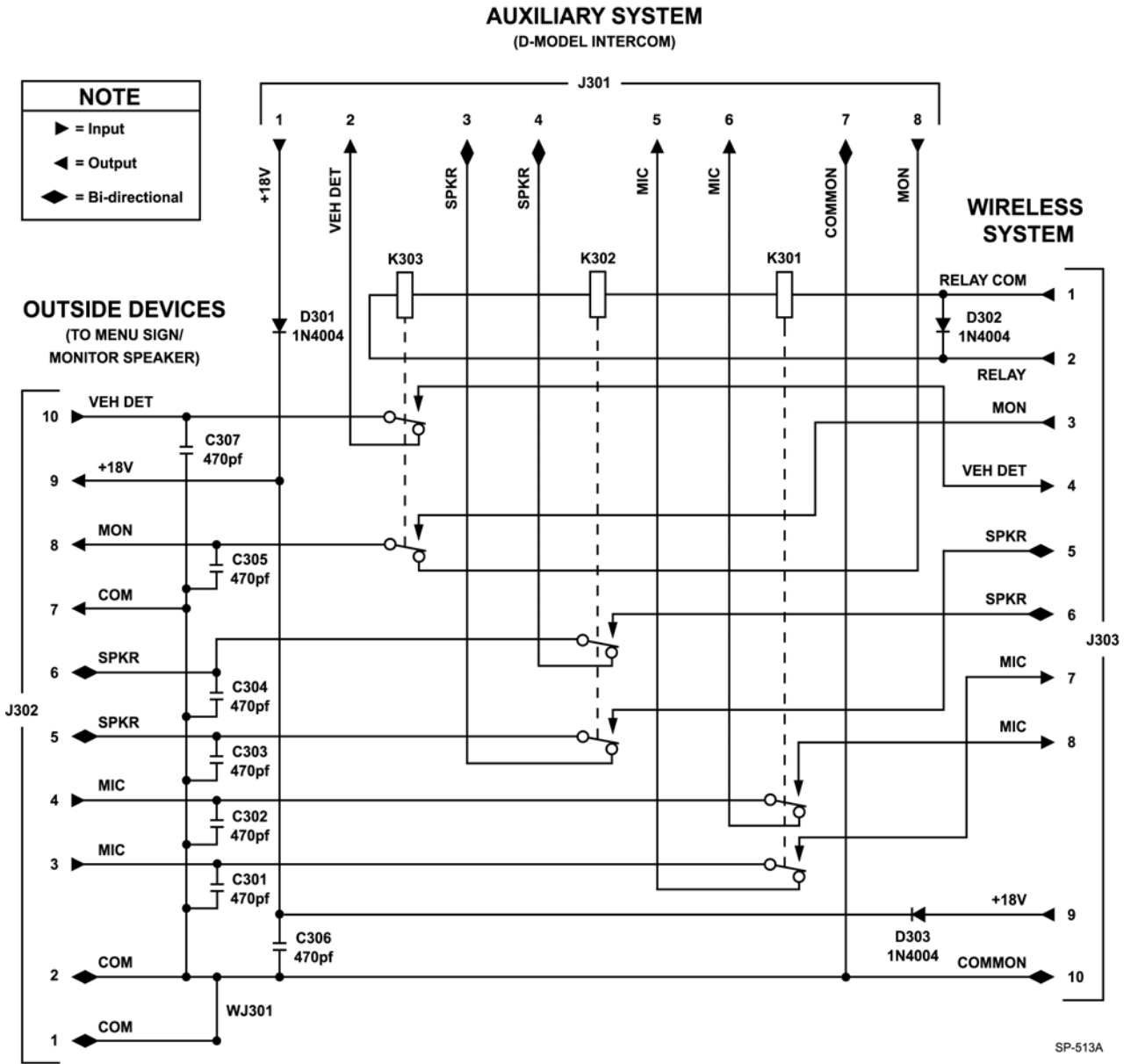

(Blank Page)